

durst

PICTOCHROM CL
PICTOCHROM +
PICTOCHROM + AF
PICTOGRAPH
PICTOGRAPH AF

Service manual

2.1

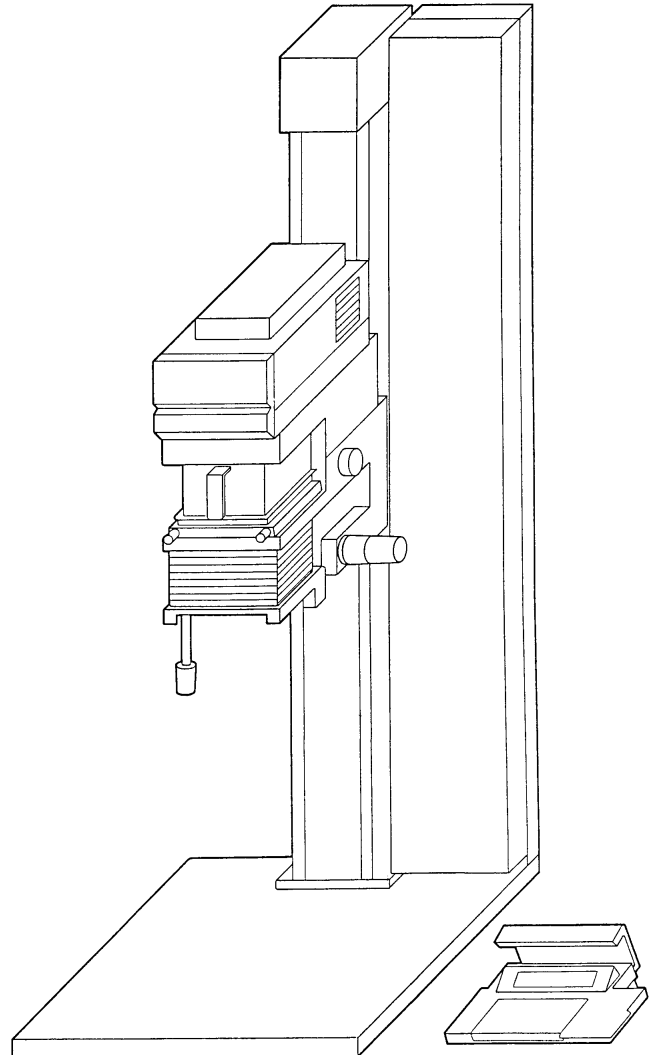

2nd EDITION; version 2.1

PICTOCHROM CL / PICTOCHROM + / PICTOCHROM + AF
PICTOGRAPH / PICTOGRAPH AF

These units, basically having the same technical construction and outfit, are all contained in this new second edition service manual.

Notice

This service manual has been edited in Mai 1996.
Updated to version 2.1 in November 1998.

Utmost care was taken to ensure a flawless manual; we are, however, most grateful for all suggestions for improvement or correction.

For your suggestions please use the enclosed reply letter.

The service manual order code number is: **SM01320**

REPLY LETTER

We' d like to receive your comments on this repair manual. Please answer the questions and return this form to:

DURST PHOTOTECHNIK AG, att. Service Department

Service manual for unit: _____

1. Version 2. Version 3. Version _____ Version

Have you found any mistakes? Which?

Did this manual help you to find an error cause?

What was the mistake?

What was the solution?

Have you suggestions concerning the completion of the manual? Which topics should be added?

SERVICE MANUAL

This manual is divided into 4 sections:

- I. **Concerns the enlarger**

- II. **VCNA-feature**
for Pictochrom + and Pictochrom + AF

- III. **AF-Control**
Autofocus mechanism for Pictochrom + AF
and Pictograph AF
 - Autofocus memory check

- IV. **Kermit Data Saving on PC**

- V. **Wiring diagrams**

Section I

Concerns the enlarger

Contents:

1 Introduction

- 1.1 System characteristics, specifications and tolerances
- 1.2 Power on cycle
- 1.3 Error messages
- 1.4 Description of PCBs
- 1.5 System descriptions through the test program
- 1.6 Connecting a roll paper easel: I/O

2 Mechanical instruction

- 2.1
 - Removing the enlarger head
 - Exchanging the counterweight spring
 - Adjusting the brake spring
 - Exchanging the rubber clutch and the drive pinion
 - Exchanging the locking knob
 - Exchanging and retensioning the lens adjustment
 - Exchanging the drive pinion or drive wheel of the lens adjustment
 - Exchanging the column sleeves - right-hand lens column
 - Exchanging the column sleeves - left-hand lens column (top)
 - Exchanging the column sleeves - left-hand lens column (bottom)
 - Exchanging the rollers
 - Exchanging the latch bolts
 - Exchanging the bellows
- 2.2
 - Exchanging the colour filters
 - Exchanging the colour filter motors and the microswitches
 - Exchanging the density filter motors
 - Exchanging the heat protection filters
 - Exchanging the shutter motor

1. Introduction

1.1 System characteristics, specifications and tolerances

Film sizes:	up to 10 x 12.5 cm (4 x 5") (roll film up to 12.2 x 12.2 cm (5 x 5"))
Column height:	148 cm (58 in.)
Max. height (with fully raised enlarger head):	174 cm (69 in.)
Baseboard size:	4 x 64 x 69 cm (1.5 x 25 x 27 in.)
Usable baseboard area:	64 x 57 cm (25 x 22.5 in.)
Optical axis / column distance:	31 cm (12.2 in.)
Net weight:	approx. 60 kg (133 lbs)
Usable focal length:	50 - 150 mm (180 mm)

Linear magnifications: manual enlarger	lens	film size	min. on	max. on	Labom
	in	in mm	baseboard	baseboard	table
	mm				max.
	150	10 x 12.5 cm (4 x 5 in.)	0.90 x	6.6 x	10.6 x
	135	9 x 12 cm (3½ x 4¾ in.)	0.80 x	7.6 x	12.0 x
	105	6x7 cm/6x9 cm (2¼ x 2¾ in. 2¼ x 3½ in.)	0.60 x	10.3 x	16.0 x
	100	6x7 cm/6x9 cm (2¼ x 2¾ in. 2¼ x 3½ in.)	0.55 x	10.7 x	17.0 x
80	4.5x6 cm/6x6 cm (1¾ x 2¼ in. 2¼ x 2¼ in.)	0.50 x	14.0 x	21.0 x	
50	24 x 36 mm	4.20 x	24.0 x	36.0 x	

Linear magnifications: Autofocus enlarger	lens	film size	min. on	max. on	Labom
	in	in mm	baseboard	baseboard	table
	mm				max.
	150	10 x 12.5 cm (4 x 5 in.)	1.0 x	6.6 x	10.6 x
	135	9 x 12 cm (3½ x 4¾ in.)	1.0 x	7.6 x	12.0 x
	105	6x7 cm/6x9 cm (2¼ x 2¾ in. 2¼ x 3½ in.)	1.0 x	10.3 x	16.0 x
	100	6x7 cm/6x9 cm (2¼ x 2¾ in. 2¼ x 3½ in.)	1.0 x	10.7 x	17.0 x
80	4.5x6 cm/6x6 cm (1¾ x 2¼ in. 2¼ x 2¼ in.)	2.6 x	14.0 x	21.0 x	
50	24 x 36 mm	5.8 x	24.0 x	36.0 x	

Job memories: 200

Power Unit:

Mains supply: 100/110/220/240 V 50-60 Hz
Voltage stabilisation range: +10 % - -15 %
Consumption: approx. 500W

Recommended climatic conditions:

Temperature: +15°C up to +30°C
Relative humidity: 5 - 95 %

Light source and illumination system:

Halogen lamp: 250 W / 24 V
Lamp life: approx. 50 h
Evenness of illumination intensity E (factor 5x f/8):
 $\varnothing E = 4.8 \text{ Lux (box 450)}$
 $\varnothing E = 33.0 \text{ Lux (box 35)}$
Efficiency η (factor 5x f/8): $\eta = 5.3 \text{ lm/kW (box 450)}$
Illumination C_c (factor 5x f/11):
 $C_c1 = \text{max. } 20 \%$
Centre - corners:
 $C_c2 = \text{max. } 5 \%$
4 corners:

Connections: Roll paper easel
Matrix printer
Measuring probe

Closed Loop system:

Maximum error after lamp change: $\pm 0.025 \text{ D at gamma 1 for positives}$
 $\pm 0.015 \text{ D at gamma 1 for negatives}$
Cold-warm drift: $\pm 0.01 \text{ D at gamma 1 and constant room temperature}$
Repeatability: $\pm 0.008 \text{ D at gamma 1}$
Colour distribution: $C_c = 0.025 \text{ D at gamma 1}$

Filters:

Maximum filter density: Pictochrom and Pictochrom +: 130 densitometric units
(1.3D) adjustable in steps of 0.001 D
Pictograph: 130 Y and 170 M

Density diaphragm in 2 steps:

step 1 0.30 D
step 2 0.60 D

Exposure time: 0.5 - 999 sec.

Gradation range: 0 - 5.0
Gradation steps: 1/10 units

Paper channels: 30 (0 - 29)
No paper channel by Pictochrom

Film channels: 9 (1 - 8) only on Pictograph

Feature of the Pictochrom CL – Pictograph

Design concept:

The **Pictochrom CL** is an improved version of Laborator 1200 and Colikit 1201.

Its advantages are the following:

- Motorised filter setting
- Closed Loop system
- VCNA mode (only + version)

The colour enlarger Pictochrom CL has been equipped with Closed Loop regulating system. During exposure, light is measured by sensors in the light mirror box as primary colours red, blue and green, and then regulated by the microprocessor.

The **Pictograph**, the B/W enlarger for variable contrast paper also uses the Closed Loop system with colour sensors for blue and green. In processing B/W contrast paper consistent light quality is also important: undesirable variations in gradation or changes in density can be avoided.

- New LCD display
- The bellows extension range has been increased. Reductions are thus possible without the extension tube (attention with AF- version)
- Built-in shutter for short exposure times, important when doing repeat printing.
- 3 additional light boxes can be used
 - Pictobox 450= standard
 - Pictobox 67= accessory
 - Pictobox 35= accessory
 - Pictobox 550= accessory
- 7 lenses can be used
 - Interchangeable lens holder round lens panel for all available lenses (50 - 180 mm) for easy control of lens aperture setting.
- Connection for a roll paper easel
- Attached sensor probe

With the **Pictograph** the contrast is measured by a sensor probe and the necessary contrast grade and exposure time is determined automatically. Each measuring result can be adjusted and corrected at any time.

With the Pictochrom + the density can be measured by a sensor probe and the necessary exposure time is determined automatically. Each measuring result can be adjusted and corrected at any time.

I-1.1.3

1.2 Power on cycle

SETUP

Switch power on. No result.

- Check fuse F1
- Check connections
- Check Picto power supply PCB

The timer counts down from 3.00 sec. to 0.00.

- N - Check microcontroller PCB
- Check Picto keyboard PCB
- Go to test 4 in the test program

The display shows:

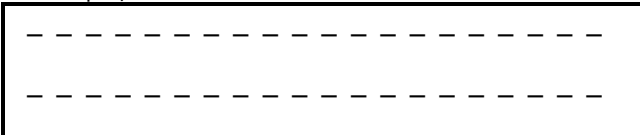

- N - Check microcontroller PCB
- Check Picto keyboard PCB
- Go to test 1 in the test program

If the shutter remains open, it will be closed during the setup cycle

- N - Check shutter connector on rear side of the colour head
- Check shutter motor
- Go to test 7 in the test program

Also the chopper in the measuring probe closes

- N - Check measuring probe for mechanical problems
- Check cable and connector
- Go to test 7 in the test program

The colour filters swing out and switch the microswitches (W. Light position)

- N - Check filter motors
- Check microswitches
- Go to tests 3, 6, 8 in the test program
- Check motor control PCB
- Check mechanical position of colour filters

The lamp goes in standby mode

- N - Check fuse F2
- Check lamp
- Check lamp stab. PCB and fuse F1 located there

The display goes to the last set filter and exposure time values. The display shows:

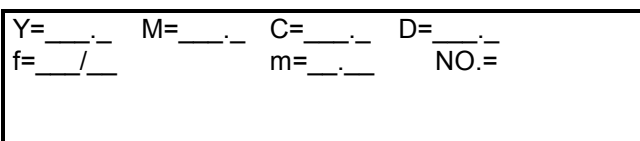

for Pictochrom CL

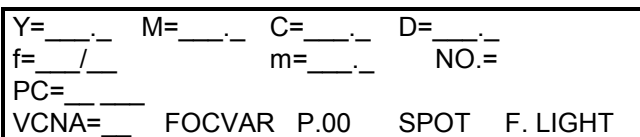

for Pictochrom +

GRADE=_. _	CONTRAST=_. _	D=_. _
f=___/___	m=_. _	NO.=
PC=___	FC= _	
GRADE	AUTOSCAN	

for Pictograph

Press the "Light" key
The lamp and fan go on

The filters swing to the set filtration values

Closed loop problems

Initialisation of the enlarger can be started from test 10 in the test program.

- N - Check RAM, battery
- Go to test 9 in the test program
- N - Check keyboard on test 3
- Go to Picto keyboard PCB
- Check lamp stab. PCB and fuse F1 on it
- N - Check measure cells.
Go to tests 15, 16 in the test program
- Check the filter motors.
Go to tests 15, 16 in the test program
- N - Check lamp
- Check lamp socket
- Check lamp voltage
- Go to test 16 in the test program

1.3 Error messages

ERROR 1

ERROR 1 - RAM memory defect - switch the power OFF and ON to check if RAM really defect - call customer service

This error message appears automatically in CL operation when internal software code words do no longer correspond. In the operation test program this error is only displayed if test 9 is selected.

Cause:

- Extremely high glitches (also caused by antistatic devices)
- Internal lithium RAM battery dead

When exchanging RAM, re-initialise the enlarger (test 10) and activate auto-offset (test 11).

ERROR 2

TEST 11 - AUTO OFFSET A / D - CONV
WARNING !! PRESS HELP KEY
ERR2 ERR2 ERR2 ERR2 ERR2 ERR2 ERR2
START EXIT

ERROR 2 only appears in the test program on the third LCD display line of test 11.

AUTO OFFSET A/D CONVERTER

Cause:

The min./max. auto-offset values of 01/320 (or 64/400 for Pictograph) are exceeded.

OFFSET voltage of one of the following OPs (V3, V5, V22 on microcontroller PCB) exceeds the tolerance ($\pm 10\text{mV}$)

The RAM memory must be initialised (see test 10) in the following cases:

- if the RAM has been exchanged
- if a new Eprom version has been fitted
- if repairs have been carried out to the microcontroller PCB (make sure data has been saved to a PC!)
- if the program has been locked by exceptionally high line disturbances, and if switching the enlarger on and off does not help
- if you unplug (keyboard, colour head, probe or roll box) under power

During RAM initialisation in test 10, offset values are erased. In this case, reset values (test 11)

ERROR 4

ERROR 4 : Color Head not connected or W. light error . Call customer service.

This error is displayed when the enlarger is switched on if the head is not connected or if the three micro-switches (Y-sw, M-sw, C-sw) can not register the white-light position. (Switching the enlarger on moves the three colour filters to the white-light position).

ERROR 5

ERROR 5 : OFFSET PROBE OUT OF RANGE -
call customer service (TEST 19)

Cause:

- Microswitches or microcontroller PCB / V37 faulty, go to test 3 in the test program
- Filter wheel has become mechanically jammed, motors out of order or motor control PCB defective (test 8, test 15)
- Spring for filter wheel has become displaced

This error message only occurs in connection with the Picto probe on the Pictograph and Pictochrom +.

Causes:

1. In test 10 - AUTO OFFSET A/D CONVERTER for density measurement is exceeding its tolerances. Values above or below 64-400 have been recorded.

Remedy:

Repeat test 11: operation amplifier V5 on microcontroller PCB may be defective

2. OFFSET of measuring probe beyond tolerance values 01-650.

Re-calibrate offset, V2 may be defective (test 20)

3. In the case of measurements with a lot of light, the probe's mechanical chopper is not absolutely accurate (test 20). Photo diode is not completely blacked out.

No light :

Switch power off and replace lamp

This error message appears when no signal is received from the measuring cells when an exposure is triggered.

Cause:

- Lamp defective
- Blown fuse (F2)
- Measuring cells faulty (colour signal PCB, test 15)
- Lamp inserted incorrectly
- Auto-offset values beyond tolerances (test 11)

Loop error :

Switch power off and replace lamp

- Lamp defect ?
- Lamp positioned correctly ?

If this error message is displayed even though the lamp is working and has been correctly inserted, the loop circuit is not functioning. This message is a consequence of the previous message.

Cause:

A difference in density occurs during comparison between desired and actual values ($>0.5 D$).

- OFFSET error of A/D converter (test 11)
- OFFSET error of colour signal PCB (check this PCB)
- A/D converter circuit defective (microcontroller PCB)
- The filter wheel disk cams must be correctly adjusted, if in doubt, carry out test 15

1.4 Descriptions of PCBs

	PICTOCHROM CL	PICTOCHROM +	PICTOGRAPH
Picto power supply PCB	AC4845A	AC4845A	AC4845A
Motor control PCB	AC4835A	AC4835A	AC4835A
Lamp EST UL 4501 PCB (old version)	1872650	1872650(+)	1872650(+)
Lamp EST UL 4501 PCB (new version)	-	MC48201	MC48201
Colour signal PCB	AL4830A	AL4830A	AL4831A
Picto probe PCB	-	MB4821A	MB4820A
Picto keyboard PCB	MA4820A	MA4820A	MA4820A
Picto microcontroller PCB	AC4830A	AC4830D	AC4830B or D*

* B version can be replaced by D version

(+) new PCB MC4820A (compatible), as from series:
 A9009 = Pictochrom +
 A9400 = Pictochrom + AF / Pictograph AF

PICTO POWER SUPPLY PCB – AC4845A

The following voltages must be present.
Measure voltages relative to P0

P4 +25 DCV ($\pm 1V$)

This voltage is required for activating the filter motors
and for the density shutter motors.

Correct ?

- N - Check mains voltage, F1, F2 on power supply PCB
- Check V8 rectifier
- Check F2 (system)
- Check motor control PCB (possibly disconnect X17 and measure signal)

P3 +12 DCV ($\pm 0.6 V$)

All components connected to the measuring system are
supplied with current on +12 V. All C-MOS components
are supplied with +12 V current.

- On colour signal PCB
- Probe
- On microcontroller PCB

Correct ?

- N - Check V1 (voltage regulator 7812 and control element)

P2 - 12 DCV ($\pm 0.6 V$)

The -12 V are used for generating the reference voltage
-0.3 V for the operation amplifier of the measuring
system.

This -0.3 V will be found on the colour signal PCB in the
probe and on the microcontroller PCB, where it is
generated

Correct ?

- N - Check V2 (voltage regulator 7912 and control element)

P1 + 5.1 DCV ($\pm 0.15 V$)

This 5 V current is used for the entire electronic system.
It is generated via an L296.

Switching on generates a reset signal.

Correct ?

- N - Check F1, V3 (L296) and wiring

Power on reset:

The "Power on reset" signal is generated via V3 (L296) on the Picto power supply PCB when the enlarger is switched on, and serves to initialise the working program; erases the registers.

This signal depends on L296, C20, R5 and is effective for 60-200 ms.

Measurable on X17/3.

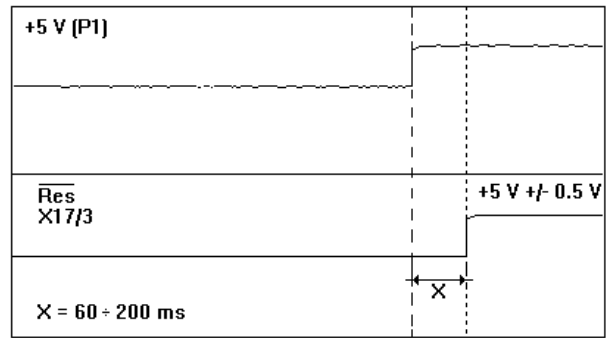

Component plan AC4845A.0Z Picto Power PCB:

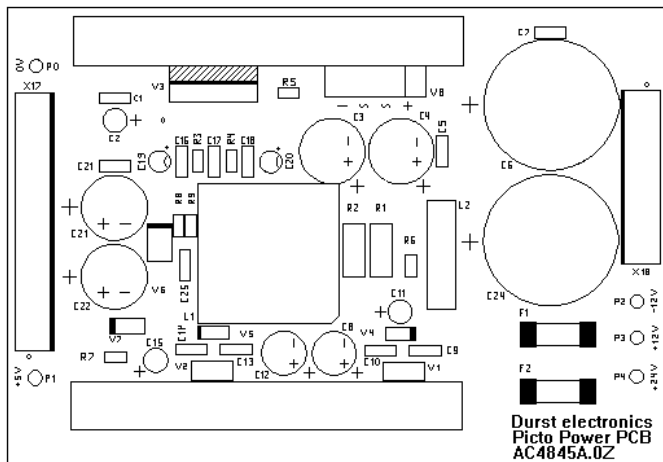

PICTO MOTOR CONTROL – AC4835A.OZ

The following voltages are to be measured against P0:

- +24 V (± 1 V) on X15/11
- + 5 V (± 0.15 V) on X16/6

The following signals are to be checked.

Oscillator signal on V2/16.

This is a saw-tooth signal with a cycle duration of 40-70 μ s and is generated by R3 and C3 (see Fig. 1).

Correct ?

- N - Check R3, C3 - V2

Synchronisation signal on V2/1.

This is square-wave signal with a cycle duration of 40-70 μ s and serves to synchronise the step-motor control module L297 (see Fig. 2).

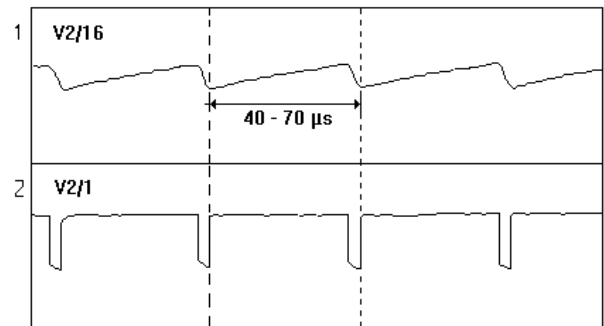

Correct ?

- N - Check V2, V7, V10

On R20, R21 /V2/15 a reference voltage of 1.35 V (± 0.06 V) must be measurable. It is generated by the voltage dividers R20, R21.

Go to test 15 in the test program.

The speed is controlled by the „+“ and „-“ keys.

- (Press „+“ to activate fast speed)
- (Press „-“ to activate slow speed)

- Check direction of rotation and speed of Y motor with B/Y keys.
- Check direction of rotation and speed of M motor with G/M keys.
- Check direction of rotation and speed of C motor with R/C keys.

Swing in density blades individually with numerical keys 1, 3 and 6.

I-1.4.4

"1" = DF 00
 "3" = DF 30
 "6" = DF 60

Correct ?

- N - Check keys, data lines, V13, V14, V15

The lamp is also switched on or off via the motor control PCB.

Lamp On Signal:

Must be 0 V to allow the lamp to burn. It is controlled via V14 and V18.

Correct ?

- N - Check data lines (test 3)
- Check V14 and V18

Standby Signal:

Goes to H-level (X13/2) when exposure is triggered. This signal is controlled via V14 and V17.

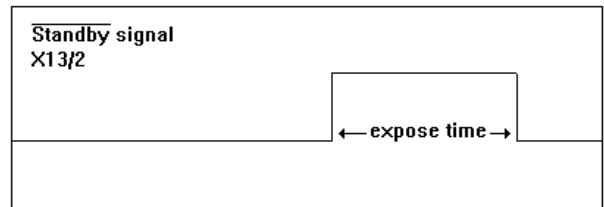

Correct ?

- N - Check data lines (test 3)
- Check V14 and V17

Should the lamp still not function, check UL 4501 PCB.

Component plan AC4835A.0Z Picto Motor Control PCB:

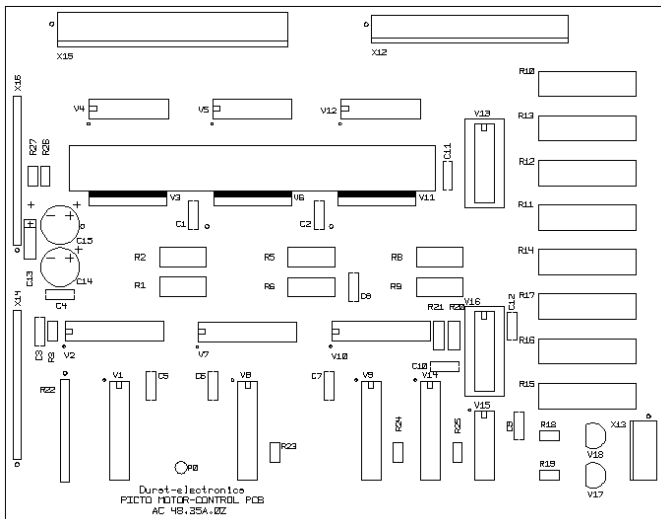

LAMP EST UL 4501 PCB - 1872650

Check the following voltages on X19.

IMPORTANT:

Measuring instruments must be earth-free.

32 V(AC) on 6/7/8a against 3a (0 V)

Correct ?

- N - Check F2 (12A T)
- Check F1
- Check transformer

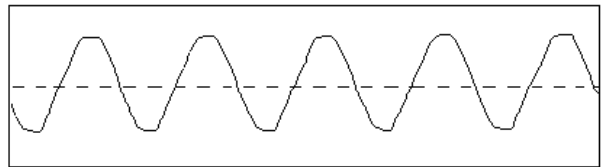

24 V(AC) on 5/4b against 3a (0 V)

Correct ?

- N - Check F1
- Check transformer

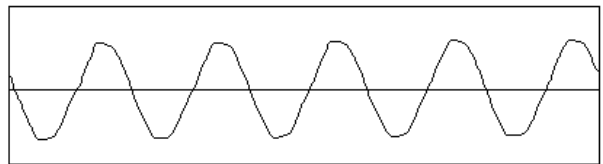

+5 V(DC) must be measurable on X19 (2b/2a) against P0 on motor control PCB.

Correct ?

- N - Go to motor control PCB (V17, V18)
- Check V17 and V18.
- Go to test 7.

Standby Signal:

X19 (1a) approaches 0 V when enlarger is switched on (preheat voltage). Opto-electronic coupler OK2 on EST PCB is activated. When switching on the light the standby signal goes to +5 V.

Lamp On Signal:

X19 (1b) approaches 0 V when lamp is switched on. Opto-electronic coupler OK1 on EST PCB is activated.

Simultaneously the fan switches on.

24 V(AC) can be measured across X19 (4a) and X19 (5a).

Correct ?

- N - Check transistor (T2)
- Check thyristor (Q2)

I-1.4.6

If lamp is switched off, voltage of the fan drops to 0 V.

Lamp:

Lamp voltage can be measured across X19 (6/7/8a) and X19 (3a). In "Standby" mode the voltage is approx. 5 V. In "Lamp On" mode it rises to 23.5 V (RMS).

23 V (RMS) should, however, be measurable on the lamp base. The voltage can be adjusted via P1. (Voltage drop on cable is 0.5 V).

This is a phase-angle controlled lamp voltage (see Fig.)

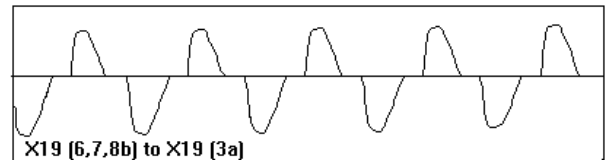

Specifications:

- Input voltage: 32 V (AC)
- Output voltage: 23.5 V (RMS)
- Type of regulation: phase chopping

- N - Check transistor (T2)
- Check thyristor (Q2)

Circuit description:

The control IC1 uses the mains voltage as supply voltage
Pin 14 - VDD
Pin 2 - VCC

- Lamp voltage can be adjusted with P1.
The voltage reaches the feedback input of IC1.
- C6 is the timing capacitor which determines the soft start slope.
- When mains current is applied, the output does not surge at once, but increases gradually until reaching the nominal voltage.
- Across C3, D3 a negative voltage is formed, taking "0" as reference, which is used as the overvoltage protection input to the U210B.
- The voltage across C4 is measured and determines the trigger delay time.
- The firing pulses are applied at pin 2 of the optocoupler OK3. The same firing pulses appear at pin 4 of this optocoupler.

Component plan LAMP EST UL 4501 PCB - 1872650:

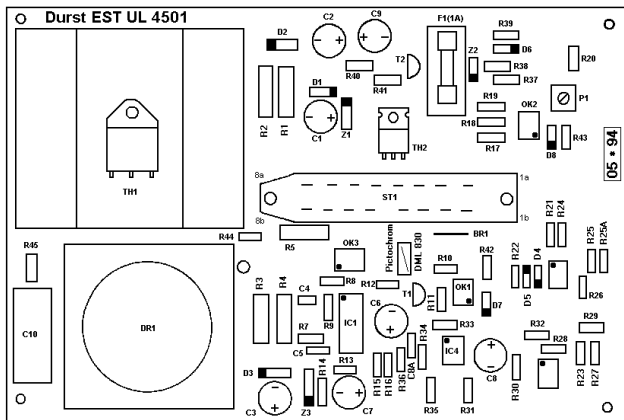

I-1.4.8

COLOUR SIGNAL PCB AL4830A.OZ - AL4831A.OZ

The colour signal PCB is situated in the enlarger head.

The following circuit boards are used:

- AL4830A for Pictochrom CL / Pictochrom +
- AL4831A for Pictograph

These circuit boards are differently equipped: different types of filters are used for Pictochrom CL / Pictochrom + and Pictograph.

If relatively large deviations and instabilities occur during processing, check the adjustment of the photoelectric cells in the light box.

Check the following voltages:

- + 12 V (± 0.6 V) on V1/7
- 0.3 V (± 50 mV) on V1/4

In order to carry out the adjustment, go to test 16 in the test program..

Measure voltage of P1, P2 and P3 relative to P0 on the microcontroller PCB.

- P1 for yellow measuring cell
- P2 for magenta measuring cell
- P3 for cyan measuring cell

OFFSET adjustment:

- Remove the colour head and position it with the fan turned upwards
- Disconnect lamp (loosen lamp base)
- Cover head with black cloth to keep measuring cells in light box darkened
- Adjust P1 (yellow) with R3
- Adjust P2 (magenta) with R9
- Adjust P3 (cyan) with R15 to 0 V ± 0.2 mV

If the offset voltage should prove unstable or no longer be adjustable, check cable to microcontroller PCB or exchange corresponding operation amplifier (V1, V2, V3 on colour signal PCB).

Amplification adjustment:

Amplification adjustment has been factory set with a test lamp, but if resetting is necessary, proceed as follows:

- Connect lamp and switch on
- Insert mixing box 450
- Switch on white light (press "W.light")
- Adjust P1 (yellow) with R4
- Adjust P2 (magenta) with R10
- Adjust P3 (cyan) with R16 to $4V \pm 0.04V$

Component plan Picto Color Signal PCB AL4830A.OZ + AL4831A.OZ:

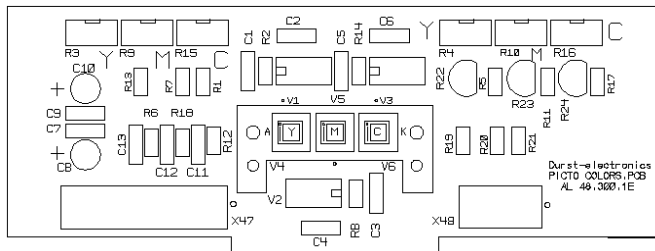

PICTO PROBE PCB MB4820A - MB4821A

The following circuit boards are used:

- AL4821A for Pictochrom CL / Pictochrom +
- AL4820A for Pictograph

These circuit boards are differently equipped: different types of filters are used for Pictochrom CL / Pictochrom + and Pictograph.

The following voltages must be measurable against P0:

- + 12 V on solder point 6
- 0.3 V on V5.

Check the following functions in the test program:

Test 3:

When the probe key is activated, the last figure displayed changes from 0 to 1.

Test 7:

Chopper and LED function correctly at 1 Hz.

Test 12:

When the photo diode is darkened, the density value in the 4th line rises to approx. 400.

Offset and amplification adjustment, or the linearity check can be carried out with test 19 or 20 in the test program respectively.

Component plan Picto Probe PCB MB4820A.0Z

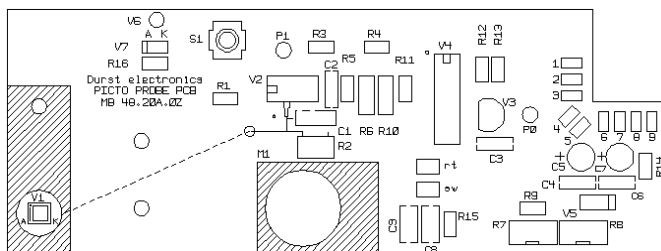

I-1.4.11

PICTO KEYBOARD DISPLAY PCB - MA4820A

Check the following voltages:

- + 5 V LED (± 0.2 V) on X31/9 against X31/8 (Gnd)
- + 5 V LED (± 0.5 V) on X31/1 against X31/5 (0 V LED)

Correct ?

- N - Check cable

Contrast adjustments of characters in the display:

- Adjustable via R16 from +5 to -600 mV
- Full contrast (-600 mV)
- No contrast (+5 V)

Correct ?

- N - Check R15, R16, C3, display

Brightness adjustment of display illumination and of the seven-segment display. This can be adjusted by potentiometer R4.

Measure on X34/1 against X34/3.

V5/1 must be adjustable via potentiometer R4 starting from fully left turned position 1.45 V (± 0.15 V) to fully right turned position 3.20 V (± 0.3 V).

On V5/7 we find the square-wave signal as shown in Fig. 1

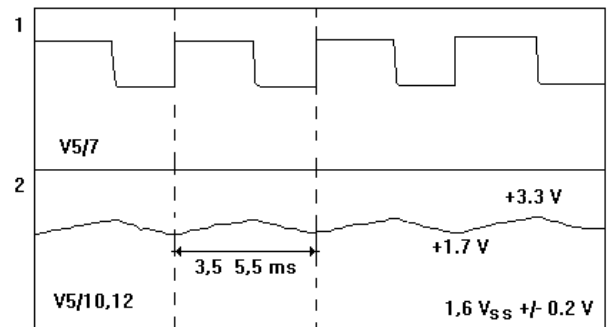

Via R10 and C2 we receive the saw-tooth signal shown in Fig. 2.

DOFF signal becomes effective during exposure. This signal switches off the display illumination via V3.

Measure on V5/8 and 14 against 0 V. V5 generates a pulse signal during full illumination (Fig. 3) and, when unlit, the output approaches +5 V.

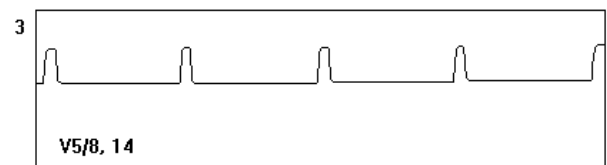

On the collector of V7 it must thus be possible to measure a signal as shown in Fig. 4 (with the 7-segment display at full illumination). When it is dark, 0 V can be measured. This signal serves to regulate the brightness of the 7-segment displays.

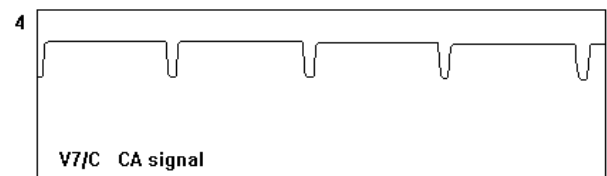

I-1.4.12

For the display illumination the following signals must therefore be measured.

On V8 emitter at full illumination strength (Fig. 5) and +5 V when dark.

To regulate the brightness of the 7-segment display and the timer display, a pulsed signal as shown in Fig. 6 is used.

At full illumination (see Fig. 6) and when completely dark, 0 V can be measured on X33/1.

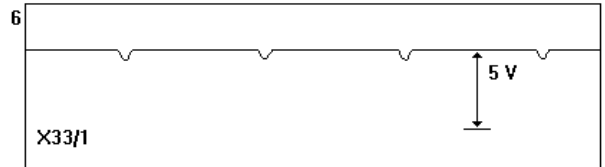
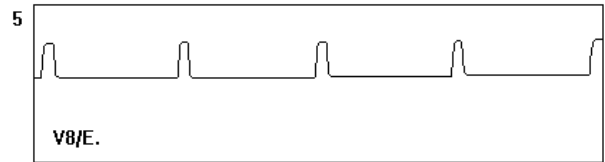

Correct ?

- N - Check R4
- Check V5, V8, V7, V17
- Check Deskill
- Check display

The keyboard can be checked in test 2.

The following components are concerned: V1, V2, V3, V4, V9.

Component plan Picto Keyboard PCB MA4820A.OZ:

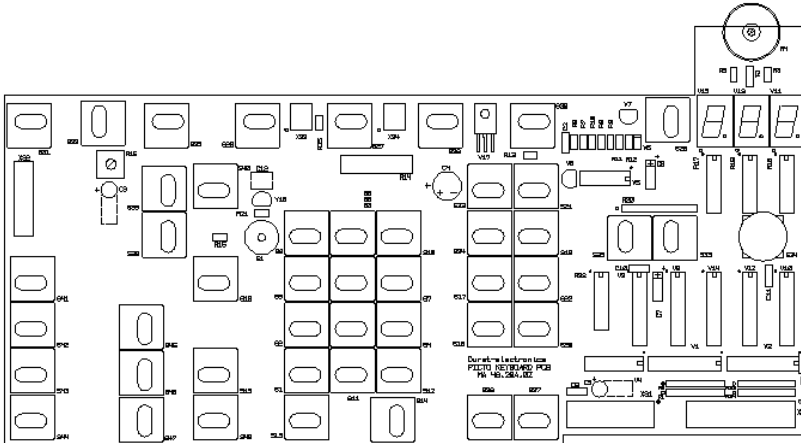

PICTO MICROCONTROLLER PCB - AC4830A / B / D

AC4830

A-Version: used only in Pictochrom CL (1 Eprom)

B-Version: used only in Pictograph (2 Eproms, motor control circuit for measuring probe chopper)

D-Version: used in Pictograph and Pictochrom + (2 Eproms, motor control circuit for measuring probe chopper, output X9 for AF-commands and factor signal input for VCNA-feature)

Note:

D -Version is compatible with the B-Version!

B-Version can not substitute D-Version and is no longer used in newer Pictograph units!

Check the printed circuit board as follows:

The following voltages are measured against P0.

5 V (± 0.15 V) on X7/6

+ 12 V (± 0.6 V) on X7/12

- 12 V (± 0.6 V) on X7/14

- 0.3 V (± 30 mV) on V31/K

Reset signal on X7/10 after switching on.

Reset on V43/1 must be delayed by 60-200 ms with mains on.

The data lines can be checked in test 3 of the test program.

Specific errors can also be rectified via the test program.

Not only this printed circuit board but all peripheral parts can be checked with the help of the test program.

Check "ERROR MESSAGES". Go to Point I-1.5 "System description through the test program".

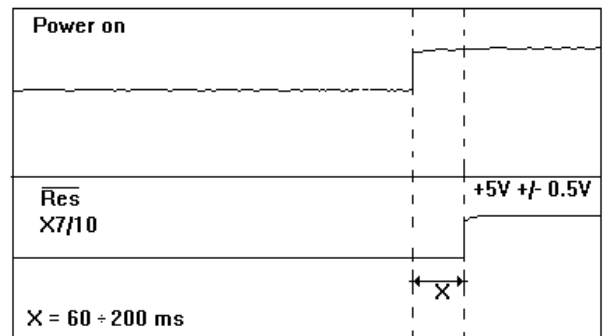

Component plan AC4830A Picto Microcontroller PCB

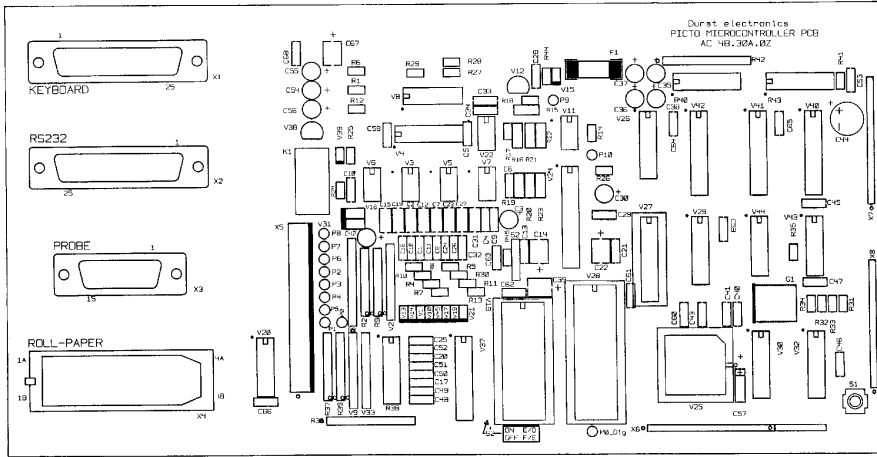

Component plan AC4830B Picto Microcontroller PCB

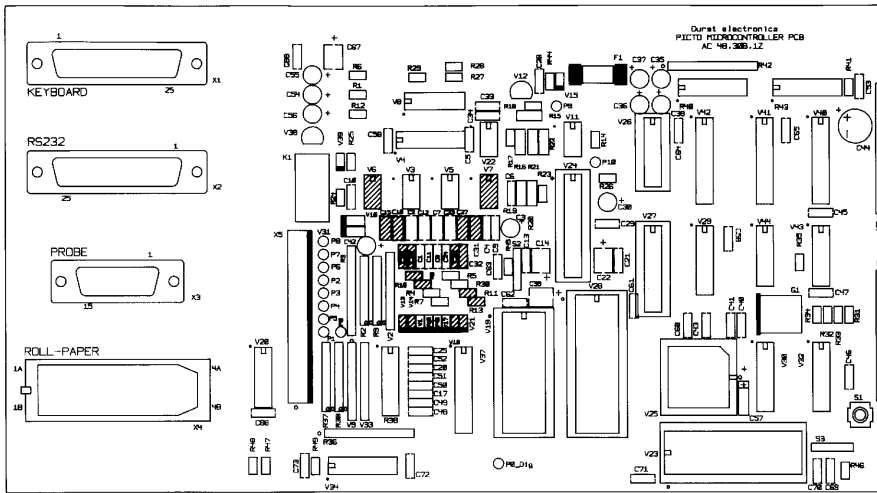

Component plan AC4830D Picto Microcontroller PCB

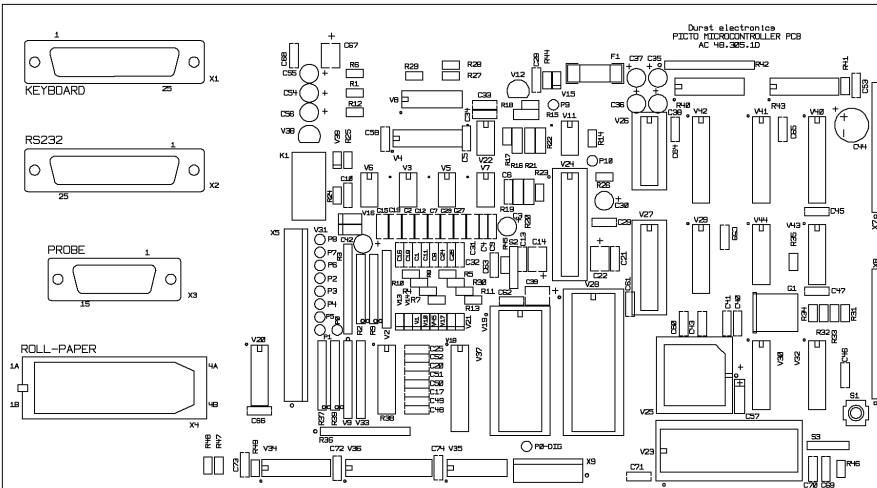

1.5 System description through the test program

To isolate the cause of a failure to a field replaceable unit, go through the following pages. Each page is made up like this:

Headline:

Summarises action and allows some parts to be skipped

Description:

Informs what must be done and how the unit must react.

Notes, failures:

Informs what to do if the machine does not react as requested. Takes a closer look at each step.

General:

The Z 80 CPU is not used as in the Pictochrom CL / Pictochrom + and Pictograph it is not possible to check the unit with the aid of addresses.

Therefore the data paths and different input and output components must be checked while the unit is on. In this case the levels can not be kept stable.

With the aid of the test program you can check virtually the whole unit and its functions.

Data and/or address lines can mostly be checked via test 3 in the test program.

Steps

1. Entry into test program
Display test

2. Keyboard test

3. V37 / input test

4. Timer display test

5. Lamp test

6. Motor test

7. Density, shutter, lamp and fan test

8. Stepper motor test

9. RAM, battery test

10. RAM function - initialisation

11. Auto offset

12. Photometer log. signals

13. Photometer lin. error

14. Continuous test filter control

15. Photometer test

16. Closed loop

17. Serial interface (RS232C)

18. Transmit / Receive RAM data

Parts under test

- Picto power supply PCB
- Microcontroller PCB
- Picto keyboard display
- LCD display

- Picto keyboard display
- Microcontroller PCB

- V37 on microcontroller PCB
- Filter (limit switches)
- Roll paper easel
- Probe
- Possible test of the data bus

- 7 segment display
- Picto keyboard display PCB

- Factory set (only with simulator)

- Motor control PCB
- Filter motors

- Density motors
- Shutter motor
- Lamp and fan

- Motors

- RAM

- RAM initialisation

- A/D converter

- Factory set (only with simulator)
- VCNA-feature (for Pictochrom +)

- Factory set (only with simulator)

- Filter-motor control

- Filter control
- Measuring cells
- Lamp

- Measuring cells
- Filter motors

- Interference of the data transfer

- Data saving with PC and "Kermit".

I-1.5.2

Only for Pictograph probe and Pictochrom + probe

19. Adjustments for measuring probe

- Measuring probe

20. Special entering in this step

- Linearity error
- Light chopper (probe)

Note:

Picto probes can be exchanged at any time without problems arising (any adjustments).

Pictochrom + and Pictograph probes are not interchangeable!

ENTRY INTO TEST PROGRAM FOR PICTOCHROM CL

Press and hold "light" and "expose" keys.
Power on.
The timer counts down from 2.99 to 0.00.
Release the "light" and "expose start" keys.

ENTRY INTO TEST PROGRAM FOR PICTOGRAPH / PICTOCHROM +

Close Dipfix switch S2 on microcontroller PCB.
Then switch on enlarger via main switch.
Test steps 1-19 thus become accessible.

The display shows:

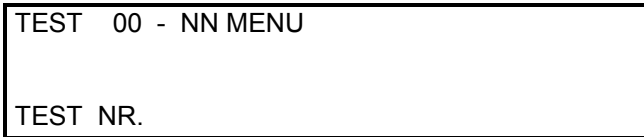

Correct?

- N - Check the contrast control (on Picto keyboard PCB)
- Check the 5 V on power supply PCB and connection to Picto keyboard PCB.

Measure + 5 V on X32/13.

Correct?

- N - Check 5 V supply
- Check the data bus on step 3

Each step of the test program can be selected directly by entering the numerical step number and pressing the softkey ← (TEST)

To exit this test step press "exit".

The display returns to the initial characters (TEST 00).

The timer display goes to 0.00.

Correct?

- N - Check R15, R16, C3, contact cable

Check data bus supplies on test 3.

Check the I/O components V2 on "Picto keyboard display PCB".

TEST 1

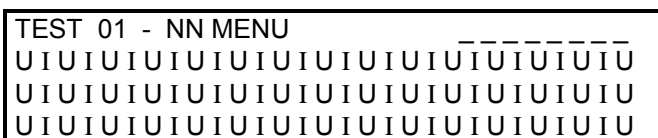

The display shows:

The LCD lines 2-4 are loaded with U and lying H.

In the right-hand corner the Eprom version of the display is shown.

Should all characters be missing check the data supplies.
They can be checked in test 3.

Correct?

- N - Check display
- Check grounding of display
- Check flat cable for display

To exit from the test step press "exit" key.

TEST 2

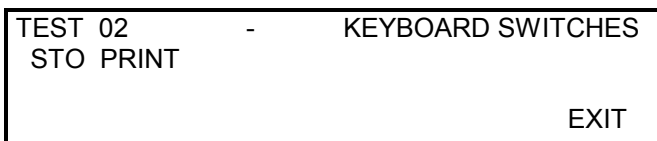

The display shows:

The keyboard is switched like a matrix:

Each key connection is in a row (horizontal) to one column (vertical).

When the "exit" key is pressed, the next step of the test program is selected.

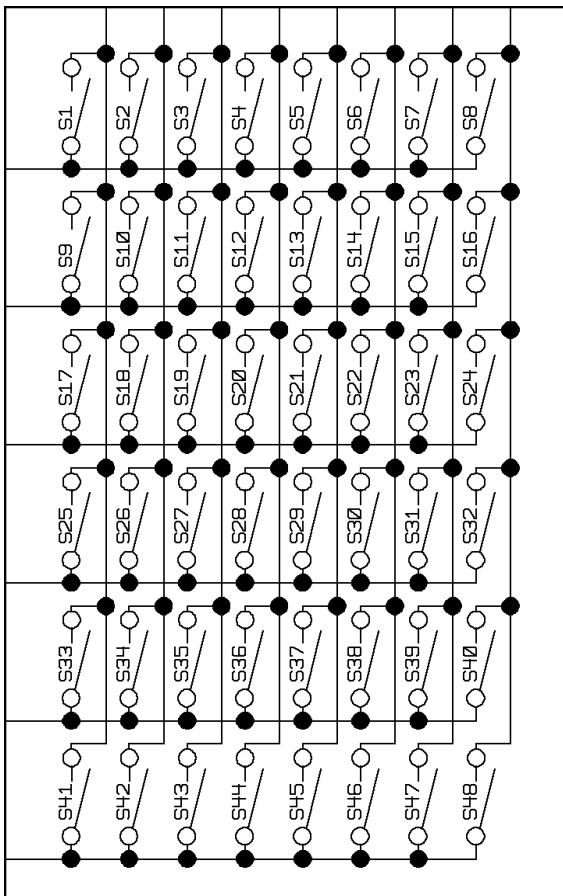

KEY	CODE WORD
S1 - 0	DIGIT 0
S2 - 1	DIGIT 1
S3 - 2	DIGIT 2
S4 - 3	DIGIT 3
S5 - 4	DIGIT 4
S6 - 5	DIGIT 5
S7 - 6	DIGIT 6
S8 - 7	DIGIT 7
S9 - 8	DIGIT 8
S10 - 9	DIGIT 9
S11 - -	-
S12 - +	+
S13 - .	.
S14 - CLEAR/STOP	CLEAR STOP
S15 - m/SIZE	M/SIZE
S16 - CHANNEL	CHANNEL
S17 - R	R
S18 - M	M
S19 - L	L
S20 - D	D
S21 - Y	Y
S22 - C	C
S23 - B	B
S24 - G	G
S25 - ←	SK1
S26 - →	SK2
S27 - ↓	SK3
S28 - ↑	SK4

I-1.5.5

KEY	CODE WORD
S29 - DISPLAY ON/OFF	DISPL ON/OFF
S31 - HELP	HELP
S32 - OPTION	OPTION
S33 - W. LIGHT	W. LIGHT
S34 - EXPOSE / START	EXPOSE START
S35 - LIGHT	LIGHT
S36 - F. STOP	F. STOP
S37 - TIME	TIME
S38 - STO / PRINT	STO PRINT
S39 - RCL SHOW	RCL SHOW
S40 - NO / ON-LINE	STO PRINT
S30 - EXIT	NO / ON LINE (*)

(*) When this key is pressed the test 00 appears on the display.

Correct?

- N A. Only one key is not recognised: check path key.
- B. One complete column of keys is not recognised: check V9 on Picto keyboard PCB.
- C. One complete row of keys is not recognised: check V3 on Picto keyboard PCB.
- D. The display shows different characters. The functions do not correspond to the key pressed: check data bus on the "Picto keyboard display PCB" (TEST 3).

TEST 3

TEST 03	-	V37 INPUTS
MSB	11100000	
		EXIT

Variable display values possible

The display shows:

This step helps to check the input/output component V37 on the microcontroller PCB.

The following signals can be checked:

- Filter limit switch
- Roll-paper easel inputs
- Probe

The data bus supplies can also be checked. On the microcontroller PCB there are the following components which correspond to each other: V40, V41, V42 on keyboard display PCB (V2, V1).

All 8 characters (0 or 1) correspond to the 8 data lines (D0-D7).

I-1.5.6

ABCDEFGH

The first 3 numbers show the position of the colour filter limit switches. If they are activated (filter out) the characters go to 1.
 The last 4 characters refer to the roll paper easel connection.

- A = Microswitch Y
- B = Microswitch M
- C = Microswitch C
- D = n.c.
- E = Shutter open (roll paper easel)
- F = Focus on (roll paper easel)
- G = Exp. start (roll paper easel)
- H = Start (probe)

If an input of V37 is connected against 0 V, the following message appears in Display "1" on the corresponding output.

Disconnect X5 MSB 00000000 (on microcontroller PCB)

- Connect start signal against 0 V (X3/4) MSB 00000001 on display
- Exp. start (roll paper) (X4/3b) MSB 00000010
- Foc. on (roll paper) (X4/1b) MSB 00000100
- Shut. open (roll paper) (X4/3a) MSB 00001000
- Display illumination and Deskill switch off.
- C limit switch (X5/3) MSB 00100000
- M limit switch (X5/2) MSB 01000000
- Y limit switch (X5/1) MSB 10000000

Correct?

- N - Check V40, V41, V42 on microcontroller PCB
- Check V2, V1 on keyboard display PCB

TEST 4

TEST 04 - 7 SEGMENT DISPLAY
 EXIT

The display shows:

The timer display shows the following cycle:

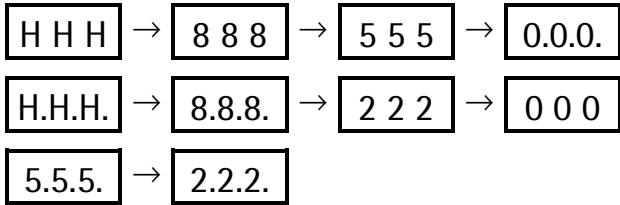

All measurements must be done on the Picto keyboard display PCB.

If no display is functioning check the contrast control (on Picto keyboard PCB).

The 3 7-segment displays V11, V13, V15 are selected through V10, V12, V14

1. If only one segment is not working
 - check the select line (display 1, 2 or 3) and V4
 - check the corresponding IC (V10, V12 or V14)
 - check R17, R18 or R19
 - replace V11, V13 or V15

If only one LED simultaneously on all displays is

2. not working
 - check data path

If only one LED on one display is not working

3. - check V10, V12 or V14
 - check R19, R18 or R17
 - replace V11, V13 or V15

TEST 5

```
TEST 05      - PRESS SIMULATOR KEYS
EXP START + START
LEDs EXP. END, RANGE, READY ON ?
EXIT
```

The display shows:

This test step can be done only with the aid of a simulator and is effected only at the factory.

Go to the next step.

TEST 6

```
TEST 06      MOTOR CONTROL LOGIC
CHECK V1 V8 V9 V14
Q0 . . . . . Q7 : 55 / AA DATA CHANGE f = 1 Hz
CLK : f = 50 KHz PULSE = 0.0005 ms      EXIT
```

The display shows:

This step is used to check the motor control PCB.

Via the data bus the data 55 and data AA are sent with a frequency of 1 Hz.

With the clock signal of 50 KHz data are switched to the motors.

In this step the filter motors make one step forwards and one step backwards at a time. Thus the motor control component (V2, V7, V10 / L297 and V3, V6, V11/ L298) can be checked.

The motors can be checked better on TEST 8.

Density shutter check on TEST 7.

TEST 7

TEST 07 - DENS 30 / 60 SHUTTER LAMP FAN ON / OFF WITH 1 Hz <div style="text-align: right;">EXIT</div>
--

The display shows:

Swing in both shutters simultaneously.
 Lamp on.
 Chopper in probe also swings in and out.

This step is used to check the density control, the lamp and the fan.

FAN ON/OFF: Not visible as the starting time for the fan is too short.

Density: V14/11

On the motor control PCB must be the following clock signal.

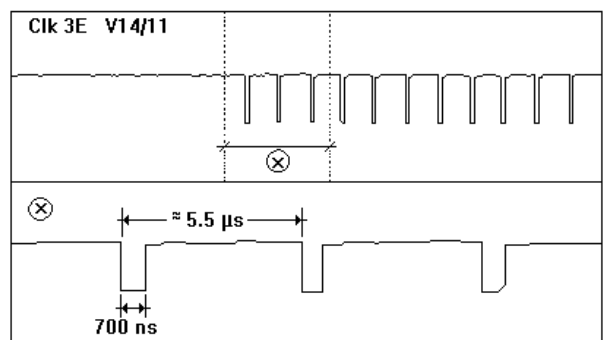

Correct?

- N - Check V32 on the microcontrol PCB
- Check cable
- Check R25, V14

The data bus must be working (you can check it via test 3).

- Drive- density shutter
- V13÷V15 determine the turning direction (in or out)
- Shutter
- At the motor the following signal must be displayed.

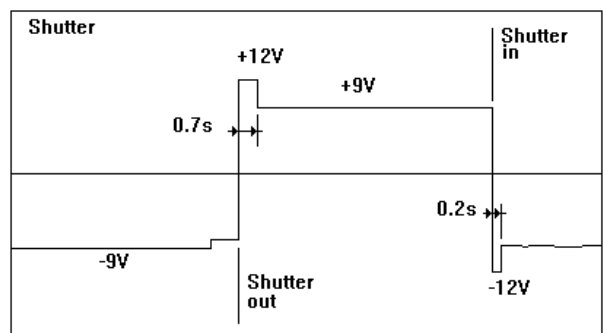

I-1.5.9

The shutter is controlled by V14, V16.

V15 is used to control the turning direction.

Correct?

- N - Check R14, R15, R16, R17
- Check for a good connection on the shutter plug

Lamp on/off

Correct?

- N - Check the lamp, fuse F2

The lamp is switched on / off by V18 on the motor control PCB. With the L-signal the lamp goes on.

If the lamp is not working, check the lamp EST PCB.

TEST 8

TEST 08	-	MOTOR TEST							
		COL.		HEAD	SWCT				
MSC	Y	---	M	---	C	---	1	1	1
				FULL	EXIT				

The display shows:

This step is used to check the 3 stepper motors and their limit switches.

With the L/D key all 3 motors can be regulated simultaneously.

With L (S19) key you can swing out the filters.

With D key (S20) you can swing in the filters.

When all filters are out, the limit switches are activated and on the display appears: **HEAD SWCT 1 1 1**.

If the filters are in, the display goes to **0 0 0**.

Correct?

- N - Check limit switches
- Check data lines, cables

With " ↑ " key (S28) you can determine the step size.

The display shows full or half (full or half steps). This can be measured on V2, V7, V10/19.

H-level: half steps

L-level: full steps

V ref. / R20/R21 $1.35 \text{ V} \pm 0.06 \text{ V}$

R1, R2, R5, R6, R8 and R9 → $4.7 \Omega \pm 0.25 \Omega$ for current limit.

I-1.5.10

The three filter motors are controlled by a CLK signal via V2, V7, V10/18.

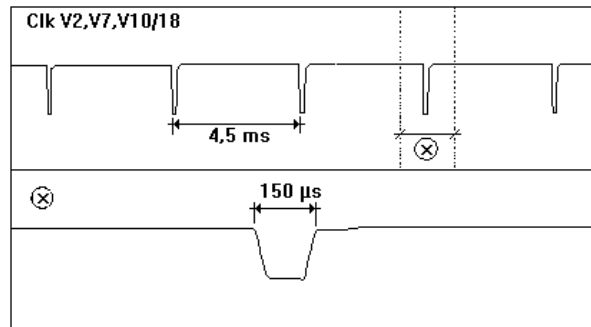

V2, V7, V10/11 (control) can be seen only if the filters are moving.

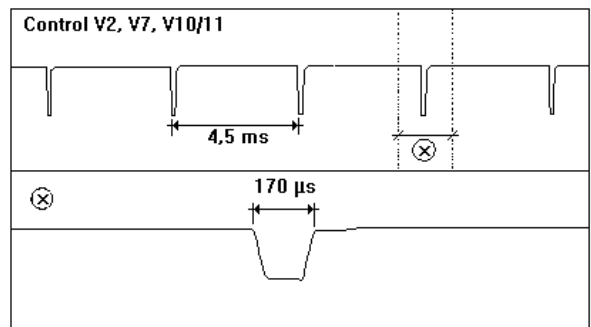

Correct?

- N - Go to Picto motor control PCB

TEST 9

TEST 09 - TEST RAM
 ERROR 1 : RAM MEMORY DEFECT, SWITCH
 THE POWER OFF AND ON TO CHECK IF RAM
 REALLY DEFECT

The display shows:

This step is used to check the RAM.

If no values are saved in the RAM or if data have been lost the display shows:

ERROR 1 - RAM memory defective

This message appears also, if the unit was just programmed - the memory can not be overwritten.

To solve this failure message, go to test 10 and initialise the RAM. Then return to this step (test 9).

```
TEST 09      - TEST RAM - BATTERY O.K.
                                                    EXIT
```

TEST 10

```
TEST 10      - RAM FUNCT. + INIZIALISAT.
WARNING !! CHANNEL DATA WILL BE LOST
DEFAULT RS232 PARAMETER WILL BE SET
                START                EXIT
```

```
TEST 10      - RAM FUNCTION O.K.
WARNING !! AUTO OFFSET cancelled !
Start AUTO OFFSET A/D conv. / TEST 11
```

The display shows:

RAM - BATTERY OK

If not, replace the RAM

The display shows:

With the softkey " ↓ " (START) the initialisation can be started. All the memory will be lost!

Attention:

The auto-offset values on test 11 will be cancelled.

Press "Start" key until the following message is displayed.

The serial interface is initialised to 1200 BAUD

Hd. Shake = DTR/DSR

If a matrix printer is connected but has not been adjusted to the above parameters, the correct parameters must be set via the program SETUP/INSTALL/RS232C.

Note:

After the RS232C parameters have been set, it is absolutely essential to switch the Picto off briefly and then on again to initialise the parameters.

The initialisation of the RAM memory is necessary if:

- the RAM is replaced
- a new Eprom version is mounted
- there are repairs to the microcontroller PCB and the data have not been saved by a PC
- the program has been blocked due to extremely high mains disturbances (if it can not be solved by powering on/off)
- if you unplug (keyboard, colour head, probe or roll box) under voltage.

TEST 11

```

TEST 11      - AUTO OFFSET A / D - CONV
WARNING !! PRESS HELP KEY
ERR2 ERR2 ERR2 ERR2 ERR2 ERR2 ERR2 ERR2
          START                               EXIT

```

```

TEST 11      - AUTO OFFSET A / D - CONV
WARNING !! PRESS HELP KEY
0260 0231 0221 0227 0243 0228 0240 0228
          START                               EXIT

```

Variable display values possible

The display shows:

If the RAM has been newly initialised via test 10, offset values will be erased.

In this test step the offset values of the colour and density input amplifiers on the microcontroller PCB can be read in anew via software.

- Unplug colour head and measuring probe connectors (X21 and X3) (not under power on!!)
- Erase old offset values with "Clear" key (3rd LCD line goes blank)
- Press "Start" key.

In the third line of the LCD display, eight values between 01 and 320 appear (for Pictochrom CL)

For the Pictograph, values of 64-400 apply.

Due to the amplification change-over of 1:16 from V22 on the microcontroller PCB there are two offset values each per colour and density.

Y Low; Y High; M Low; M High; C Low; C High; D Low; D High

If the min./max. values of 01/320 are exceeded, "ERR.2" is displayed.

In this case the offset voltage of one of the OPs V3, V5, V22 on the microcontroller PCB exceeds the permissible tolerance (± 10 mV).

These values can not be adjusted. Check the OPs with the peripheral components. Then connect colour head and probe again.

TEST 12

```

TEST 12      - FOTOMETER MODE
LOG. SIGNALS Keys : 0 / Clear
Factor A/D = _ _ _ _ _      L = _ _ _ _ . _ _
Y, M, C, D  _ _ _ _ _ . _ _ _ _ _

```

3. LCD line - VCNA part: see section II

The display shows:

In this test the measured values for the individual filters can be checked. The filters cannot, however, be adjusted. (Applicable only in connection with simulator).

Test step only carried out at the factory.

TEST 13

```

TEST 13      - FOTOMETER LIN. ERROR
1. PRESS 9V KEY + HOLD Clear
2. KEEP PRESSING 45mV + HOLD      EXIT
Y, M, C, D  _ _ _ _ : _ _ _ _ : _ _ _ _ : _ _ _ _ :

```

The display shows:

The purpose of this test is to check the amplification change-over. This requires a simulator which is only used at our factory.
Go to next test step.

TEST 14

```

TEST 14      DAUERTEST FILTERSTEUERUNG
FULL STEPS
M S C      Y _ _ _ M _ _ _ C _ _ _      5000
                                           EXIT

```

The display shows:

Beginning with 5000, counts backwards in ones after each cycle.
All three filters (Y, M, C) are simultaneously moved in and out from 0 to 210 in steps of 30.

This enables the filter motor control to be checked.

Via this test step, motors and motor control elements can be checked.

The CLK signal for Y, M, C must be H, controlled via microcontroller PCB V25, V32

TEST 15

```

TEST 15      STEP COUNTER + FOTOMETER
KEYS: L/D, B/Y, G/M, C/R, 1/2/6, +/-
0/Clear Y _ _ M _ _ C _ _ RESET EXIT
DF :      _ _ _ _ : _ _ _ _ : _ _ _ _ : _ _ _ _ :

```

The display shows:

Test 15 enables the filter motors and the filter disk cams to be checked.

Check lamp. Switch on lamp via "light" key.
Measure voltage on lamp socket, terminal X49.

Lamp on: 23.5 V ± 0.2 V RMS (TRUE RMS)
Lamp off: 5 V ± 1 V

The lamp is controlled by the microprocessor via V32 on the microcontroller PCB. (CLK 3E signal = X14/4).

The control signal passes via data line D1 to V14 and transistor V18 to the motor control in EST 4501 PCB.

The lamp is protected by fuse F2 (12 A) at the plug input.

Speed of filter adjustment is controlled via the „+“ and „-“ keys.
("+" = rapid adjustment)
("-" = fine adjustment)

Check direction of rotation and speed of the Y motor with the B/Y keys.

Check direction of rotation and speed of the M motor with the G/M keys.

Check direction of rotation and speed of the C motor with the R/C keys.

All three colour filters can be adjusted simultaneously with the L/D keys

Activate L key until Y, M, C values are at zero.

Density filters 30 and 60 can be checked with the help of the numerical keys 1, 3 and 6.

Press "Clear".

The display shows:

DF :	39.0	39.0	39.0
------	------	------	------

The base value "39.0" can differ up to ± 10.0 .
Measured values: tolerance ± 10 . This value depends on the characteristics of the lamp (reflector).

If this value is different from 39, in the normal program the effective exposure time has a bigger differences to the set exposure time.

Cause: light deviations caused by the lamp will be compensated by the exposure time.

Press 1: DF:00 00.0 00.0 00.0 (± 0.2)

Press 3: DF:30 30.0 30.0 30.0 (± 4.0)

Press 6: DF:60 60.0 60.0 60.0 (± 4.0)

Press 1: DF:00 00.0 00.0 00.0 (± 0.5)

Checking the mechanical filter adjustment (checking the cams)

Adjust counters with "L" and "D" and check the following table. Press "0" before adjusting each counter.

Counter	Difference values
00	0 - 0 +
60	16 - 40 +
120	18 - 40 +
180	18 - 40 +
240	18 - 40 +
300	18 - 40 +
360	18 - 40 +
420	18 - 40 +
460	10 - 30

Check absolute measured values with "Clear" key. These must be within the range of 200-260.

When adjusting 10 steps on a counter, for colour filter, difference value may be within the range 1.5÷8.0. Press "0" before each adjustment.

Check absolute measured values with "Clear" key.

1. Zero all counters with the "L" key to give all measured values 39.0 (± 10.0)
- 2a. Set M counter to 460 with "M" key
Measured value > 225.0
- 2b. Set M counter to 00 with "G" key
Measured value 39.0 (± 10.0)
3. Set Y counter to 460 with "Y" key
Measured value > 200.0
4. Set C counter to 460 with "C" key
Measured value > 220.0

TEST 16

TEST 16	CL	H	Eteff =	
TV y, m, c	0070	0070	0000	
0 0 1				
	MSC	YMC	LER	EXIT

The display shows:

With test 16 the Closed Loop system can be checked.

Checks can be carried out via:

- LER: Loop error
- YMC: Measuring cells
- MSC: Filters (mechanical position)

The three 001 bits show which filter is in "white light" position or which microswitch is being activated.

LER

This test is used for checking the Closed Loop System's precision.

A filtration is given. The unit filters the light and makes a "should be/as is" comparison to have exact light steadily. The values in the 3rd LCD display line go against 0 (± 0.3), that means the filters are adjusted to the densitometric value and the deviation (LER) is displayed. This helps to check if the Closed Loop system recognises colour changes, if it corrects them and adjusts deviations.

- Press "White light"
- Press "Light"
- Press softkey "LER" (\uparrow)

Display shows.:

TEST 16	CL	H	Eteff =	
TV y, m, c	0070	0070	0000	
0 0 1	+001	+001		
	MSC	YMC	LER	EXIT

Input the values (command values) in the table with the help of the numerical keyboard and the Y, M, C filter keys, and check 3. LCD line. Test with a colorimeter

YEL	MAG	CYAN
000	000	000
30	30	00
60	60	00
90	90	00
130	130	00
155	155	00
00	00	30
00	00	60
00	00	90
00	00	130
00	00	130
30	00	130
60	00	130
90	00	130
130	00	130
00	30	30
00	60	30
00	90	30
00	130	30
00	170	30

The above-mentioned values are to be input. As the filters adjust themselves, the values in the third LCD line go to 000.0 (± 0.3) in each case

These values give the loop error "LER". The maximum permissible loop error "LER" is ± 0.3 .

If there are bigger divergencies and fluctuations check the following points:

Closed loop error: check whether the lamp is defective or incorrectly inserted.

If this error message occurs, when the lamp is neither defective nor incorrectly inserted, the control circuit is not functioning.

Possible faults:

- Offset error of A/D converter (see test 11)
- Offset error of colour signal PCB.
(Adjustment see Picto colour signal PCB)
- A/D converter defective (see test 12/13)
- The disk cams of the filter wheels must be correct - if in doubt, carry out test 15.

YMC

Via "YMC" the measuring cells can be checked for correct operation. YMC gives the measured values of the proportions of light.

TEST 16	CL H	Eteff =		
TV y, m, c	0070	0070	0000	
0 0 1	+96.0	+95.9	+96.1	
	MSC	YMC	LER	EXIT

Variable display values possible

So the correct calculation of the variable display values possible measuring values will be checked (for example amplification change)

- Press "White light"
- Press "Light"
- Press "YMC" softkey (↓)

PICTOCHROM CL / PICTOCHROM +

TEST 16	CL H	Eteff =			
TV y, m, c	0070	0050	0000		
0 0 1	+115.3	+95.2	+45.0		
	MSC	YMC	LER	EXIT	

Variable display values possible

Start off with the filter value that indicates 0.
Input the following filter values:

Y = 70 M = 50 C = 0

Check measured (actual) values in the 3rd LCD line.

Measured value C = 39.0 + approx. 6.0 secondary densities

Measured value M = Measured value C + 50 (± 0.3)

Measured value Y = Measured value C + 70 (± 0.3)

Note:

The basic value "39.0" may deviate by ± 10.0. For calculation purposes, the value indicated must be taken.

If an error occurs, check offset, amplification and measuring cells (TEST 11, 12, 13, 15)

PICTOGRAPH

TEST 16	CL H	Eteff =			
TV y, m, c	0129	0000	0030		
0 0 1	+175.7	+46.7	+77.7		
	MSC	YMC	LER	EXIT	

Variable display values possible

Start off with the filter value that indicates 0.

Input the values for gradations "0" and "5" and check measured values in the 3rd LCD line.

Gradation 0:

Y = 129 M = 0 C = 30

Measured value M = 39.0 + approx. 8.0 secondary densities

Measured value Y = Measured value M + 129 (± 0.3)

Measured value C = Measured value M + 30 (± 0.3)

Gradation 5

Y = 0 M = 170 C = 30

TEST 16	CL H	Eteff =			
TV y, m, c	0000	0170	0030		
0 0 1	+50.8	+220.9	+81.0		
	MSC	YMC	LER	EXIT	

Variable display values possible

Measured value $Y = 39.0 + \text{approx. } 12.0 \text{ secondary densities}$

Measured value $M = \text{Measured value } Y + 170 (\pm 0.3)$

Measured value $C = \text{Measured value } Y + 30 (\pm 0.3)$

Note:

The basic value "39.0" may deviate by ± 10.0 . For calculation purposes, the value indicated must be taken.

If an error occurs, check offset, amplification and measuring cells (TEST 11, 12, 13, 15)

MSC

The mechanical setting of the colour filters can be checked via "MSC".

In this case the adjustment of the filters to the mechanical position can be checked.

Input filter values using the numerical keyboard and the Y, M, C filter keys, switch on the light and check the filter settings in the 3rd LCD line.

When filter move to setting filtration, the count values on the 3. LCD line count to zero (± 0.2)

If a filter moves undefinably to and from without locating in a fixed position, check the following:

- Measuring cells
- Filter wheels for mechanical jamming
- Spring on filter wheel for dislocation (audible rattling)

```
TEST 16 CL H Eteff =
TV y, m, c 0000 0000 0000
0 0 0 +000.2 +000.3
MSC YMC LER EXIT
```

Variable display values possible

TEST 17

```
TEST 17 - RS 232C
Start Start
TRANSMISSION STOP ECHOLOOP EXIT
```

Dummy plug connection

The display shows:

Interface output (RS 232) can be checked for resistance to faulty data transfer via a dummy plug.

Enter the main program via "001" SETUP/ INSTALL/RS232.

Select RS232C and set Handshake signal to XON/XOFF via „+“ and „-“ key. If necessary correct Baud. Then return to test program and attach bridging plug.

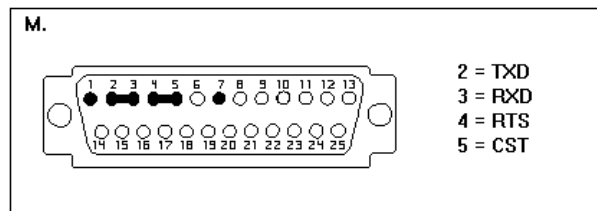

```

TEST 17 - RS 232C / TRANSMISSION
The QUICK Brown Fox Jumps Over The Dog !
Total = _ _ _ _ Error = _ _ _ _ Ber = _ _ . _ _ %
                STOP                EXIT

```

The test can be started via the "Start/ Transmission" key.

The display shows:

"Total" registers the state of the signals sent.

The number of errors occurring can be checked via "Error". The cycle can be interrupted by means of the "Stop" key.

If problems on the enlarger with transmission occur, check the following:

- Correct connection cable
- F1 (100 mA) on microcontroller PCB
- V25 or V26 on microcontroller PCB
- if the receiver is functioning

In connection with Optocable and a Durst enlarger the signal transfer can be made over 2 units by "START ECHOLOOP"

TEST 18

```

TEST 18 - TRANSMIT / RECEIVE RAM DATA
          TO / FROM A PC
_ _ _ _ Byte
          TRANSMIT      RECEIVE      EXIT

```

The display shows:

Via Test 18, data storage can be effected via a PC with "Kermit".

The following steps must be carried out:

1. Enter via "001" in SETUP/INSTALL/RS232
Set RS232 to the following parameters:
 - 1200 Baud
 - Handshake XON/XOFF
 - Time out 5 sec
 - Switch enlarger on/off (to initialise interface) and enter the test program by simultaneously pressing "Light" and "Expose" keys.
 - Select test 18
2. Load "Kermit" into PC
System diskette on the left - Kermit on the right
 - B: (press „Return" after all PC commands)
 - Kermit
 - Set speed 1200 (loading time 3 1/2 minutes - only 600 or 1200 baud possible with Picto)
3. Send data to PC
PC:
 - Log session picto
 - Connect

Picto:

- Press „Start“ TRANSMISSION
- Press „Stop“ when number of bytes reaches zero

PC:

- Press "Ctrl" and "+" simultaneously
- Press "C" (cursor moves to command line)
- Close session

4. Receiving data from PC

Picto:

Press Start RECEIVE

PC:

- Transmit picto (or other file name used)
- Type q command when number of bytes on Picto reaches zero (exits Kermit)
(To exit PC system: press "Ctrl", "Alt" and "Del" simultaneously)

TEST 19

```
TEST 19 - 1. Adjust Trimmer R7 ( left )
TEST 11 = _____ OFFS PROBE= 15 +/-10 = ____
2. Adjust Trimmer R8 ( right ) :
W. Light of 1 Lux = 152.2 D +/- 1.0 D = _____
```

The display shows:

This test only applies to the Pictograph and Pictochrom +. Its purpose is to adjust the measuring probe.

You're recommended to send the probe back to the factory for precise adjustment.

The Picto probes can be exchanged one by the other without problems.

TEST 20

```
L. AF _____ / V28 TEXT: _____ / V23
For accessing to set of test 1 - 19
Switch power off and close switch S2 on
the microcontroller PCB. TEST 20: R + L , B
```

The display shows:

In test 20 the linearity of the probe can be checked. In order to get into test 20, S2 on the microcontroller PCB must be opened.

When switching the enlarger on, keep "Expose/Start" and "Light" keys depressed.

```
TEST 20 - PROBE D = 04 - 404 / _____
OFFSET TEST 11 64 - 400 / 0E0DAHex
OFFSET PROBE 01 - 650 / _____ D/F OFFS. = ____
LinSign 0 - 61000 / 0____Hex EXIT
```

Then press "R" and "L" keys simultaneously.

Before the "B" key is pressed, with light has to be switched on via the "W. light" key. Then press key "B".

How to proceed:

LED on probe must light up. Activation of the probe key causes the LED to go out and the chopper is opened (can be heard).

The probe key must be pressed every time a measurement is taken.

Move the head to the middle position.

- Using the diaphragm, set a value of 005 on the testing probe (in line 1) (A).
Place a neutral density filter 2 over the measuring cell and note value (B).
The following difference in density (D1) must result:

A	005
B	approx. 205

D1	200 (± 4)

- Using the diaphragm, set a value of 190 on the testing probe (A).
Place a neutral density filter 2 over the measuring cell and note value (B).
The following difference in density (D2) must result:

A	190
B	approx. 390

D2	200 (± 4)

The difference between the two densities D2-D1 may not exceed ± 3.

Note:

If the linearity error is greater, the 1:10 range switching of the probe must be checked. The switching point is at a density of D = 130 (change-over voltage value 0.4 V /4.0 V)

- Check the auto offset (TEST 11)
- Check V5 and periferic components on micro-controller PCB.

Checking the mechanical light chopper:

- Using light box 35, expose the probe to approx. 100 LUX.
- Press and release probe measuring key. No error message should occur.

ERROR 5 – OFFSET PROBE OUT OF RANGE

Causes:

1. If a lot of light is present, the mechanical chopper does not completely darken the photo diode.

Use "exit" key to return to normal program. Switch enlarger off. Check for mechanical jamming.

2. If light is off. Auto offset values (test 11 Offset) outside tolerance (test 11 64-400) or Offset of measuring probe outside range (01-650, 3rd LCD line).

Readjust Offset, balance again if necessary. V5 on microcontroller PCB may be defective (test 11 incorrect).

1.6 Connecting a roll-paper easel: I/O

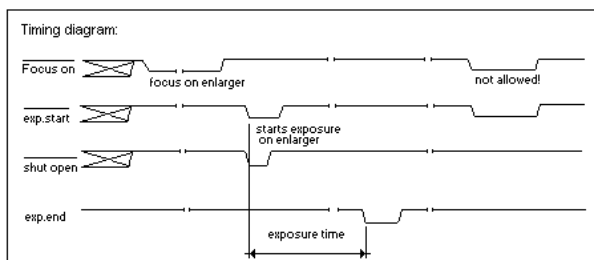
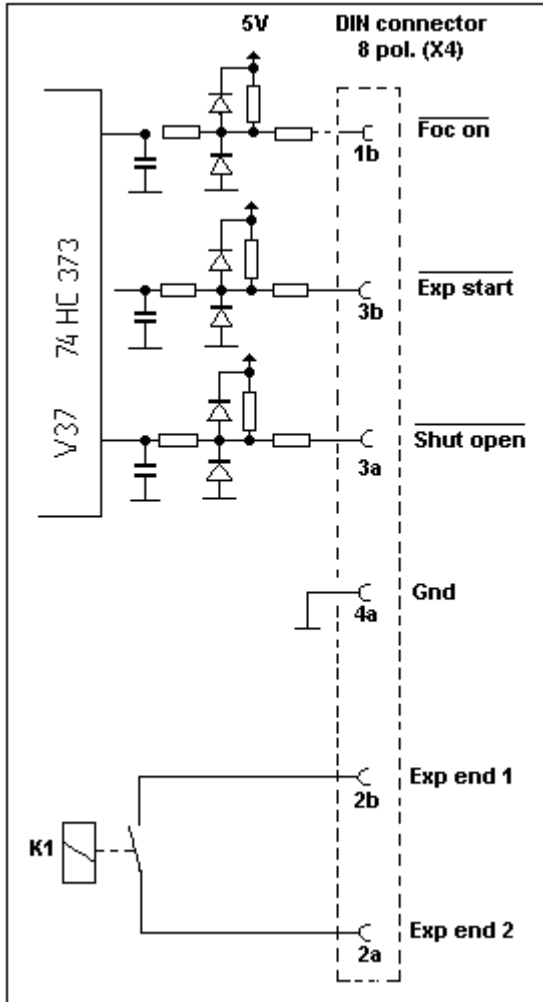

A roll-paper easel can be connected to the Pictochrom CL, Pictochrom + and Pictograph by means of an eight-pin DIN plug (X4).

The pin allocations are as follows:

- „Shut open“ X4/3a input signal
- „Focus“ X4/1b
- „Exp. start“ X4/3b
- „Exp end 1“ X4/2b output signal
- „Exp end 2“ X4/2a

The otherwise familiar "Ready" signal is not employed on the Pictochrom CL, Pictochrom + and Pictograph. The enlarger does not need a "Ready" signal in order to recognise control signals.

"Focus" signal

The "Focus" signal is used to adjust and check the focusing. When the key is activated, the signal on X4/1b is drawn towards 0 V for a short time (L-active signal) and the enlarger switches unfiltered light on. If the "Focus" key is pressed once more, the lamp goes out again.

"Exp. start" signal (200 - 500 ms)

When the "Expose" key on the paper easel is pressed, the level on X4/3b is drawn from +5 V towards 0 V for a short time (L-active). This switches the enlarger lamp on, the light is correctly filtered and exposure is started.

After the exposure sequence, which is controlled by the microprocessor, the "Exp. end" signal is sent back to the roll paper easel.

"Exp. end" signal (0.5 s)

The "Exp. end" signal is an acknowledgement signal from the enlarger to the roll paper easel.

This signal can be measured via the microprocessor (V25), V38 and K1 on microcontroller PCB on X4/2b or X4/2a. The signal jumps briefly from 0 V towards + 5 V (H-active).

This signal causes the processor of the roll paper easel to start the exposure procedure and the paper feed cycle.

If problems with the enlarger occur, test 3 in the test program can be used. In other cases the roll paper easel must be tested separately.

Operating instructions for connecting roll paper easel.

1. When working with a Papermot, burning-in is only possible in combination with manual operation.

Reason:

When automatic operation is selected, paper feed is triggered after every exposure.

2. White light is automatically activated when roll paper easel is set to "Focus on".
3. Please remember in connection with the roll paper easel that the console illumination is not switched off when the shutter opens. If, however, the roll paper easel is to send a control signal to switch off the console lighting before the shutter opens, this signal can be effective as "Shut open" signal.
4. Multiple exposures are not possible with roll paper easel and autoprint. The cassette would jam.

Set Autoprint to OFF in option mode.

Note:

Autoprint is unsuitable for multiple exposures.

2. Mechanical instructions

- 2.1
 - Removing the enlarger head
 - Exchanging the counterweight spring
 - Adjusting the brake spring
 - Exchanging the rubber clutch and the drive pinion
 - Exchanging the locking knob
 - Exchanging and retensioning the lens adjustment
 - Exchanging the drive pinion or drive wheel of the lens adjustment
 - Exchanging the column sleeves - right-hand lens column
 - Exchanging the column sleeves - left-hand lens column (top)
 - Exchanging the column sleeves - left-hand lens column (bottom)
 - Exchanging the rollers
 - Exchanging the latch bolts
 - Exchanging the bellows

- 2.2
 - Exchanging the colour filters
 - Exchanging the colour filter motors and the microswitches
 - Exchanging the density filter motors
 - Exchanging the heat protection filters
 - Exchanging the shutter motor

Removing the enlarger head

1. Raise enlarger head to its highest position.
2. Remove lens, negative carrier and mixing box, and remove plug for shutter and enlarger head (X21).
3. Release screws (1) and remove enlarger head.
4. Release screws (2) and remove pressure spring (3).
5. Completely unscrew securing knob (4) and pull enlarger head mounting outwards to remove.

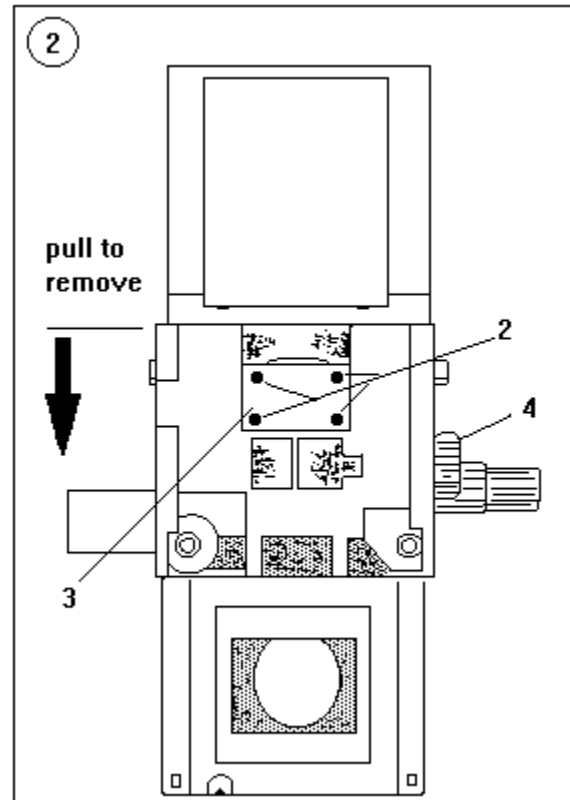
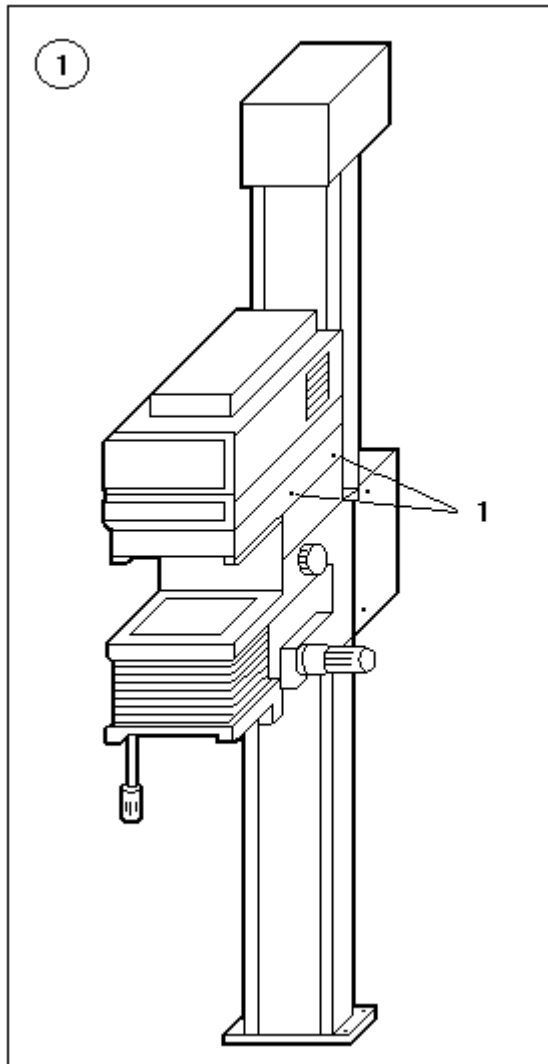

I-2.1.1

Exchanging the counterweight spring

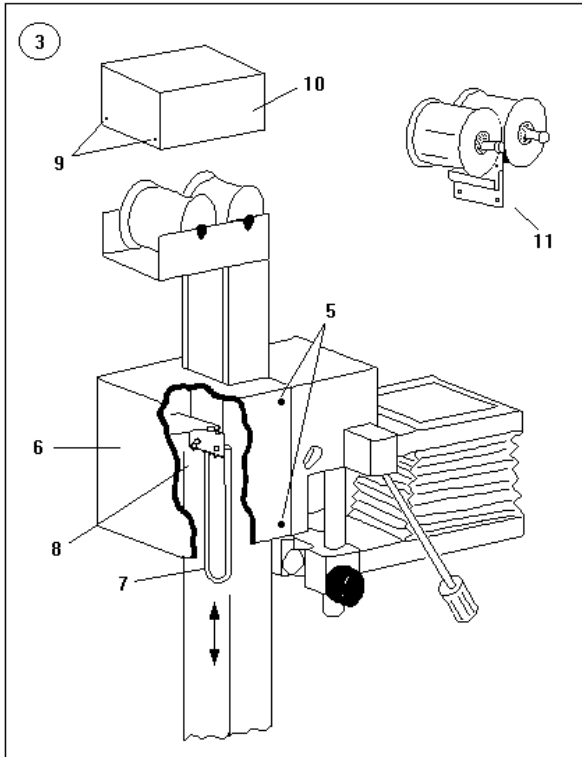

1. Raise enlarger head to its highest position.

Important:

Lock head with adjustment knob

2. Release screws (5) and remove hood (6).
3. Remove negative carrier and light box.
4. Hook special tool (7) into spring (8).

Caution:

Take the necessary care when tensioning and releasing the spring.

5. Pull special tool (7) and spring (8) downwards. Slowly release the spring.
6. Release screws (9), remove cap (10) and exchange spring bracket.

When inserting new spring, check that it is well secured.

7. Balance counterweights in such a way that the enlarger head can be adjusted smoothly.

Adjusting the brake spring

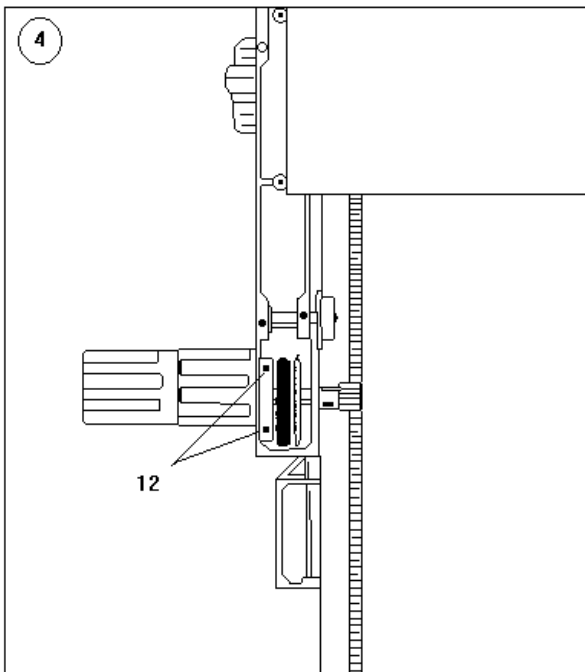

1. Release screws (5) and remove hood (6) (see Fig. 3).
2. Tighten grub-screws (12) until the brake operates as required.
3. Replace hood (6).

Exchanging the coupling brake lever. (Exchanging the rubber clutch and drive pinion).

Illustration A

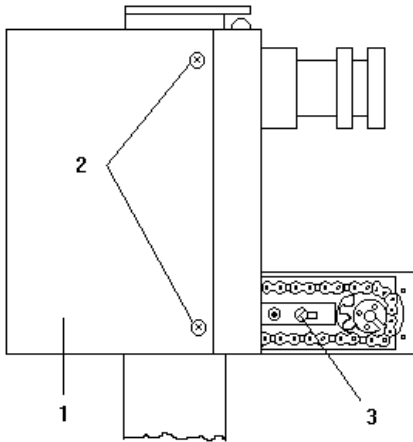

Illustration B

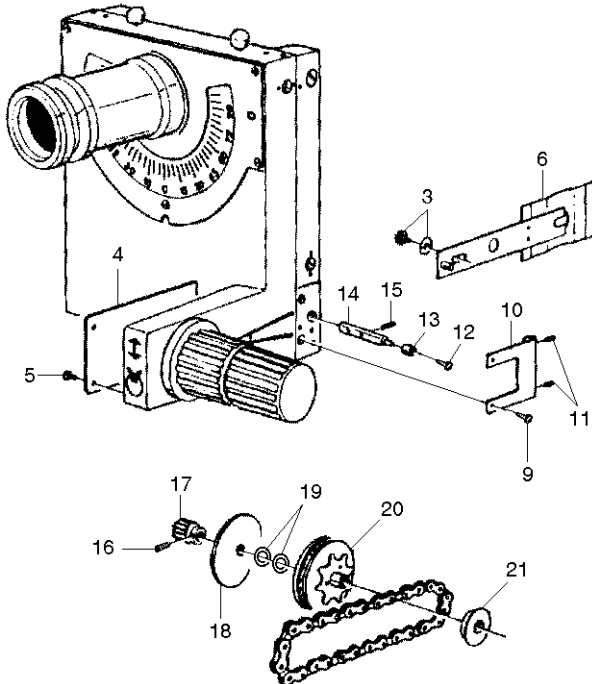
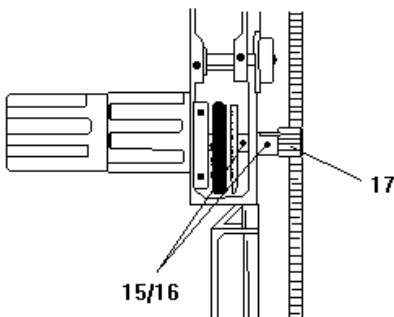



Illustration C



 **Raise enlarger head to its highest position !**

1. Remove the covering (1) by loosen the screws (2).
2. Remove also the 3 screws (5) and the cover plate (4).
3. Unscrew and remove the screw and the washer (3).
4. Remove than the 2 screws (9) and the angle (10).
5. Now beat out the spring dowel sleeves (15+16), see illustration for their location.
6. Screw a M2 screw (12) into the axle (14) and pull-out both parts and the bushing (13) with the aid of a pincers.
Attention! Don't loose the parts (17 - 21).
7. Replace now the broken lever (6) and fix the new part with the screw and washer (3).
8. Re-insert the axle (14), the bushing (13) and pay attention to the correct position of the parts 17 - 21, the spring disks (19) must be in right place and the coupling disk (18) must be clean and without grease or dirt.
9. Find the correct position of the holes on the axle to be able to beat-in the spring dowel sleeves (15+16).
10. Remount the angle (10) and if necessary adjust the grub screws (11) until the brake operates as required.
11. Mount all covers.

Exchanging the rubber clutch and the drive pinion

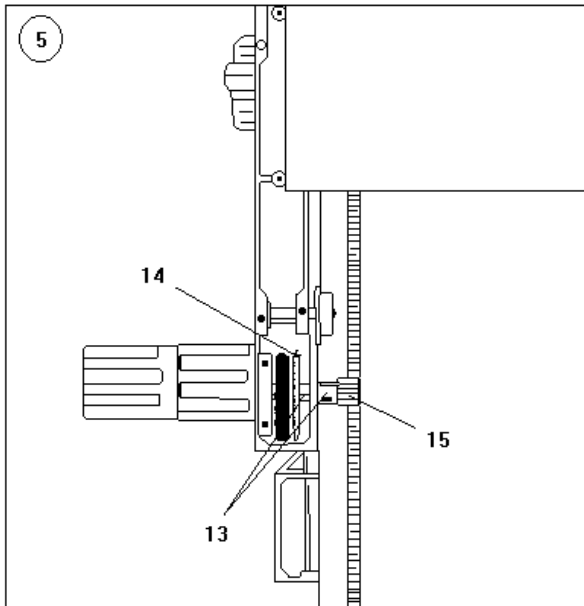

1. Raise enlarger head to its maximum height.
2. Release screws (5) and remove hood (6) (see Fig. 3).
3. Drive out clamping sleeves (13), push out shaft and exchange rubber clutch (14) or drive pinion (15).

Exchanging the locking knob

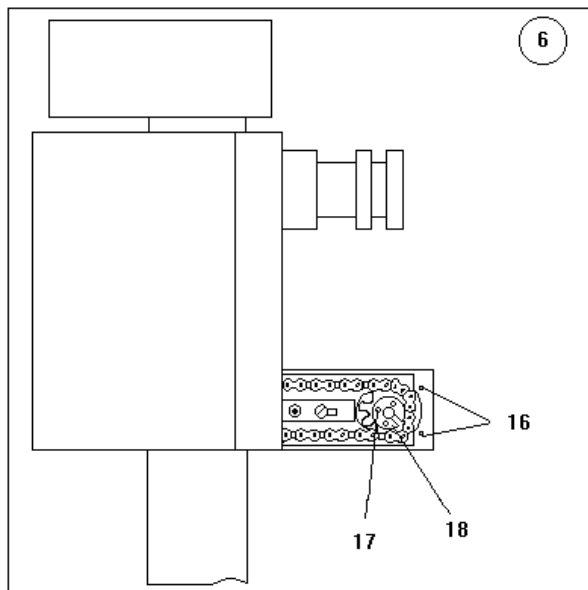

1. Raise enlarger head to its maximum height.
2. Remove negative carrier and light box.
3. Remove screws from item 16 and take off cover plate.
4. Release screws (17) and drive out locating disk (18).
5. Pull knob (19) off and exchange locking knob (20).

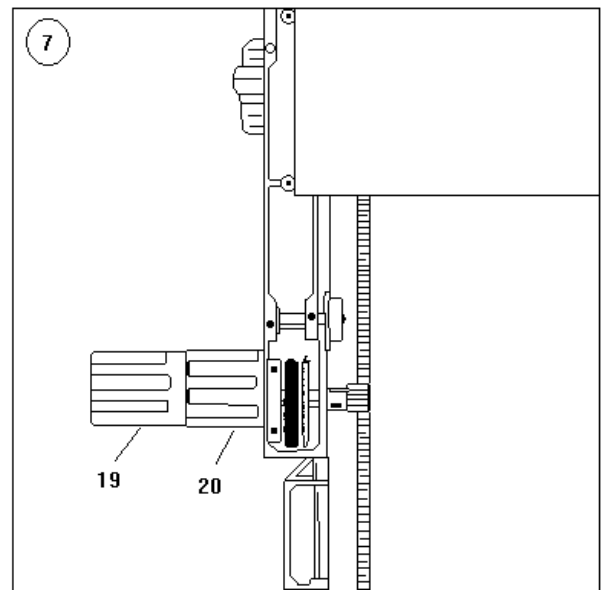

I-2.1.3

Exchanging and retensioning the lens adjustment

Exchanging and retensioning on the main body

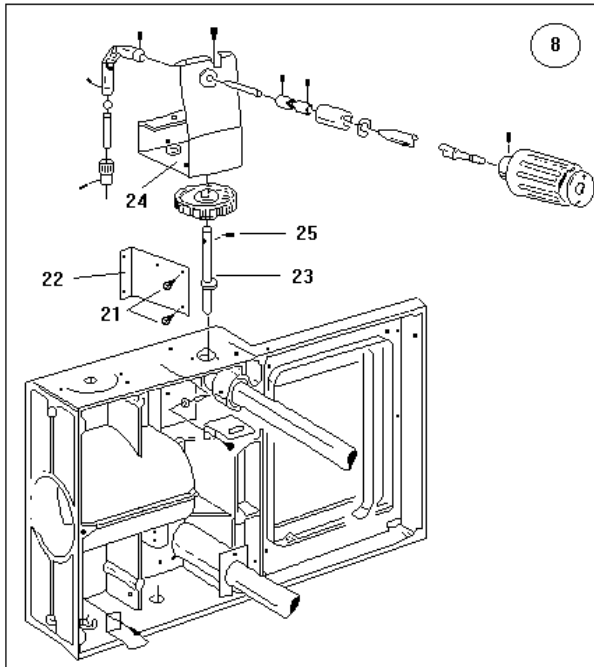

1. Lower lens holder to lowest position.
2. Release screws (21) and exchange defective friction spring (22) or friction shaft (23).
3. To do so, release screws (24).
Remove entire adjustment knob assembly.
4. Drive out spring sleeve (25) and exchange friction shaft (23).
5. Retensioning can be carried out by means of screws (21).

Exchanging and retensioning on the lens carrier

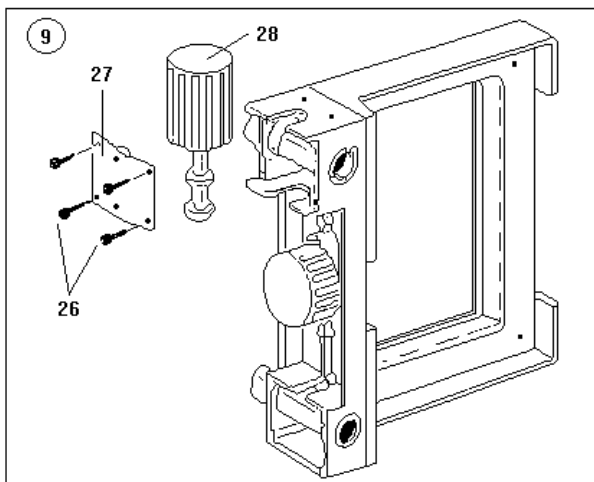

1. Lower lens holder to lowest position.
2. Release screws (26) and exchange defective friction spring (27) or friction shaft (28).
3. Retensioning can be carried out by means of screws (26).

Caution:
The friction springs (22) and (27) may only be tightened with the screws (21 + 26) enough to hold the loaded lens carrier stationary in any desired position. Excessive tightening of the friction springs (22 + 27) leads to premature wear of the sliding pads, friction shafts and column groove.

Exchanging the drive pinion or drive wheel of the lens adjustment

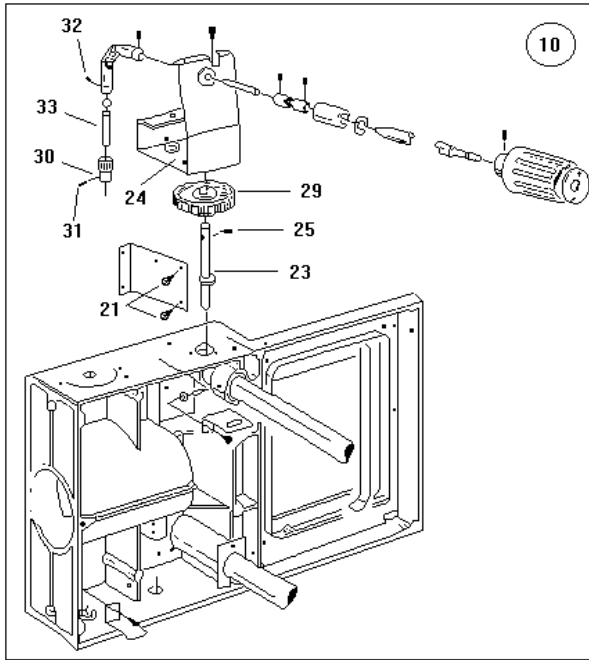

1. Lower lens holder to lowest position.
2. Release screws (21)
3. Remove entire adjustment knob assembly via screws (24).
4. To replace toothed wheel (29), drive out spring sleeve (25). Remove toothed wheel from friction shaft (23).
5. To replace pinion (30), drive out spring sleeve (31). Release the two grub screws (32) and pull out shaft (33). The pinion (30) can now be exchanged.

Exchanging the column sleeves - right-hand lens column

1. Raise enlarger head to its maximum height.
2. Remove negative carrier and light box.
3. Remove enlarger head.
4. Release screws (35), pull off top guide sleeve (36) and exchange.
5. Remove locking screw (37).
6. Loosen grub screw (38) and remove right-hand column (34) downwards. Then exchange bottom guide sleeve (39) in the same way as the upper sleeve (36).

Caution:

The friction spring (27) may only be tightened with the screws (26) enough to hold the loaded lens carrier stationary in any desired position. Excessive tightening of the friction spring (27) leads to premature wear of the sliding pads, friction shafts and column groove.

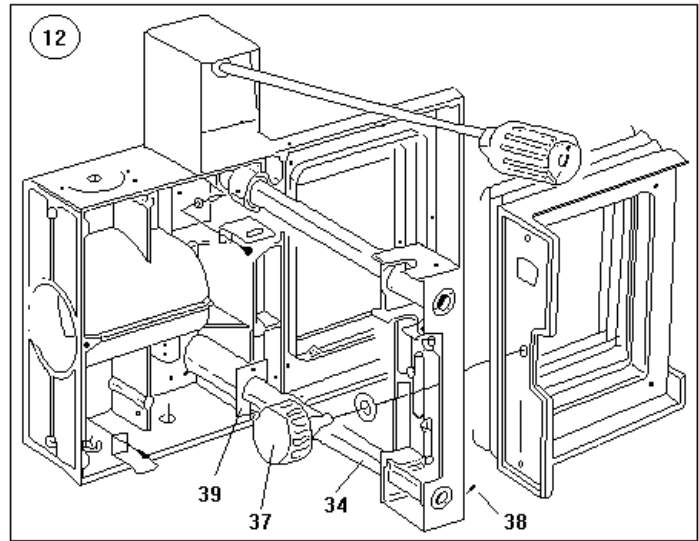
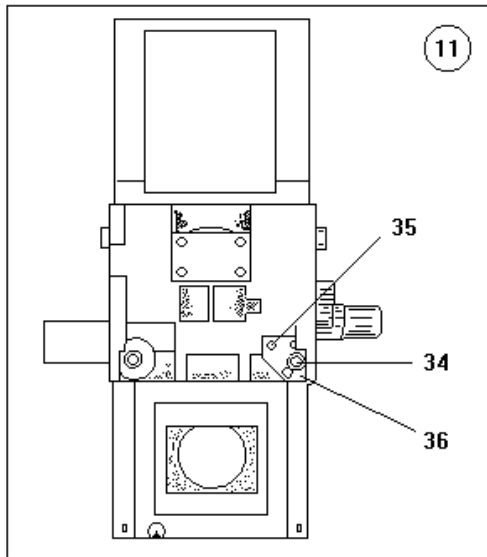

Exchanging the column sleeves - top left-hand lens column (40)

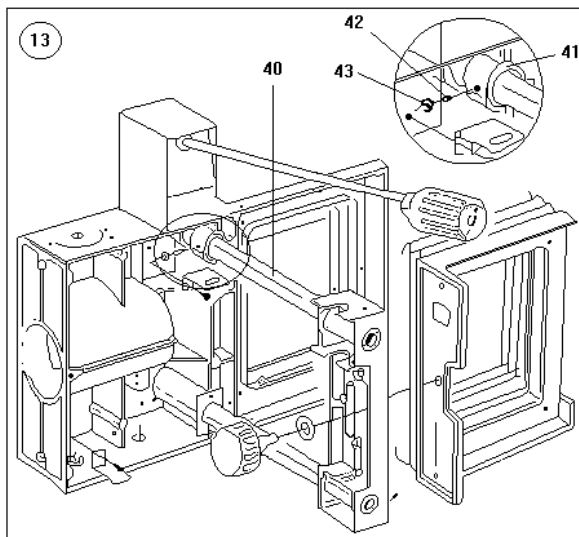

The top left-hand lens column sleeve (41) cannot be exchanged. The sleeve has been pressed into place and subsequently countersunk.

1. Retensioning the sleeve (41) is effected by means of a grub screw (42) secured by a locknut (43).
2. Release locknut (43) and tighten grub screw (42).
3. Then re-secure with the locknut (43).

Exchanging the column sleeves - bottom left-hand lens column (40)

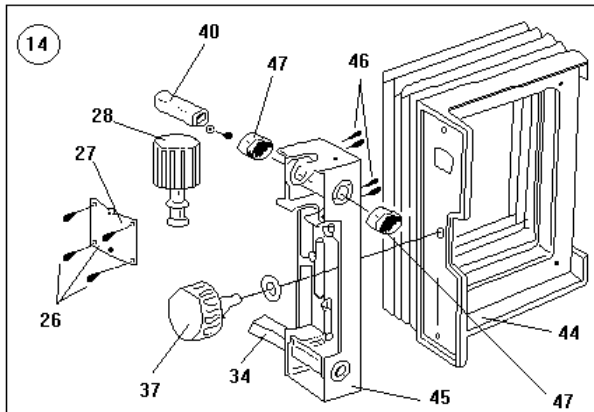

1. Lower enlarger head to its bottom position.
2. Remove locking knob (37) completely, thus releasing lens carrier (44).
3. Unscrew friction spring (27). Remove friction shaft (28) and simultaneously withdraw lens carriage (45) downwards together with right-hand column (34).
4. After loosening grub screws (46), drive out sleeves (47) and replace them.

Caution:

The friction spring (27) may only be tightened with the screws (26) enough to hold the loaded lens carrier stationary in any desired position. Excessive tightening of the friction spring (27) leads to premature wear of the sliding pads, friction shafts and column groove.

Exchanging the rollers

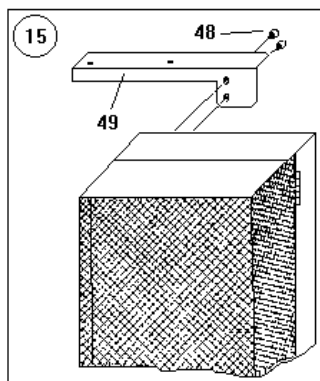

1. Remove counterweight springs (11) in accordance with instructions (2.1.1).
2. Release screws (48) of holding bracket (49).
3. Dismantle spring retainer (50).
4. Remove enlarger head (51) upwards of the column.
5. Remove rollers (52) and replace them.

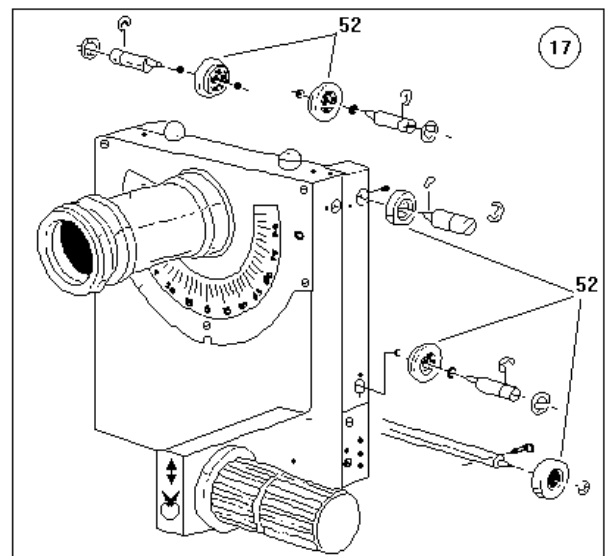
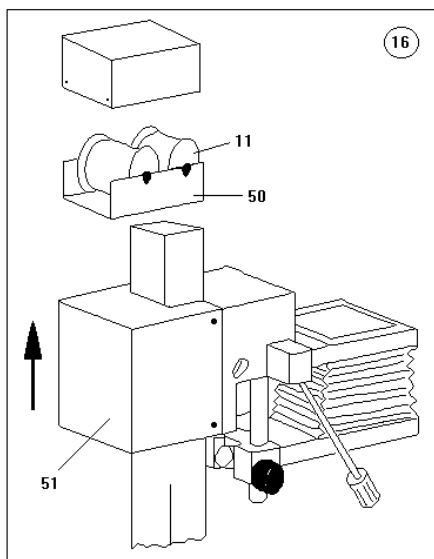

I-2.1.7

Exchanging the latch bolts

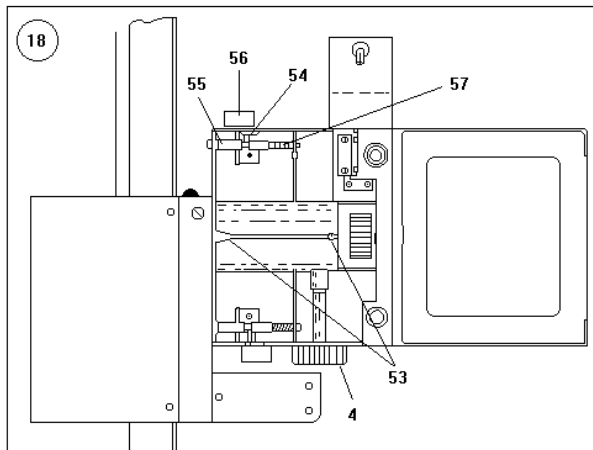

1. Remove screws from item 53 and take off cover plate.
2. Swivel enlarger head through 30°, securing it with the locking knob (4).
3. Press off locking ring (54) of the bolt (55) to be replaced, pull eccentric knob outwards slightly, and pull out latch bolt (55) towards the back.
4. Slide spring (57) onto new bolt (55) and re-assemble in reverse order.

Exchanging the bellows

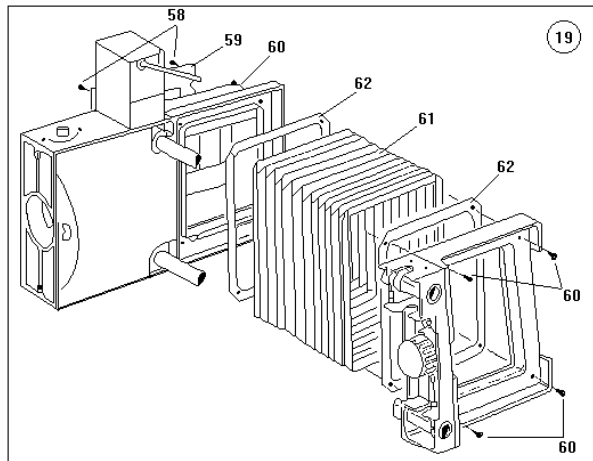

1. Raise enlarger head to its maximum height.
2. Remove negative carrier and light box.
3. Release screws (58) and remove lamina (59).
4. After releasing the screws (60) at the top and bottom ends of the bellows, fold bellows (61) and remove it.
5. Fit bellows frame (62) to new bellows (61) and secure the latter in place once more.

Exchanging the colour filters

1. Open enlarger head.
Take off hood (1), cover (2) and front plate (3).
2. Release holding plate (4) via screws (5).
3. Release and remove Y (6) and C (7) filter holders via securing disk (8) and M filter holder via securing ring (10).
4. Insert colour filters (11, 12, 13) by raising securing spring (14).

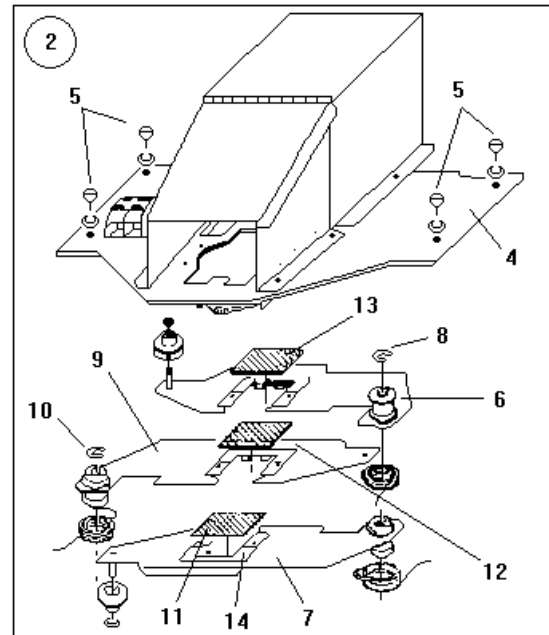
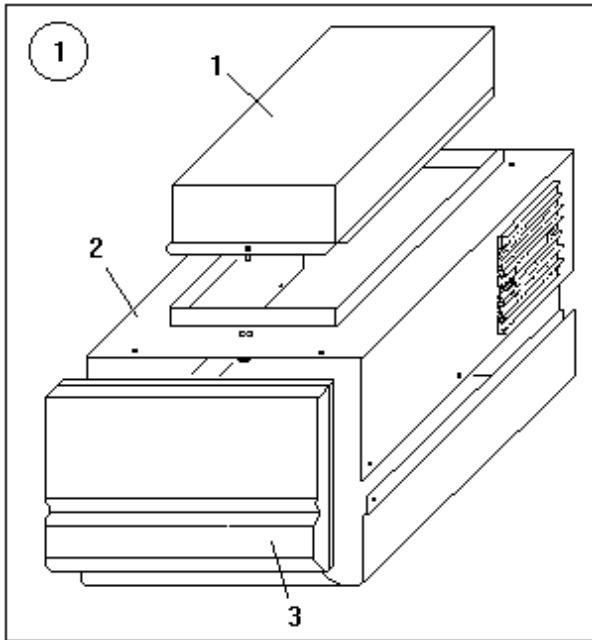

I-2.2.1

Exchanging the colour filter motors

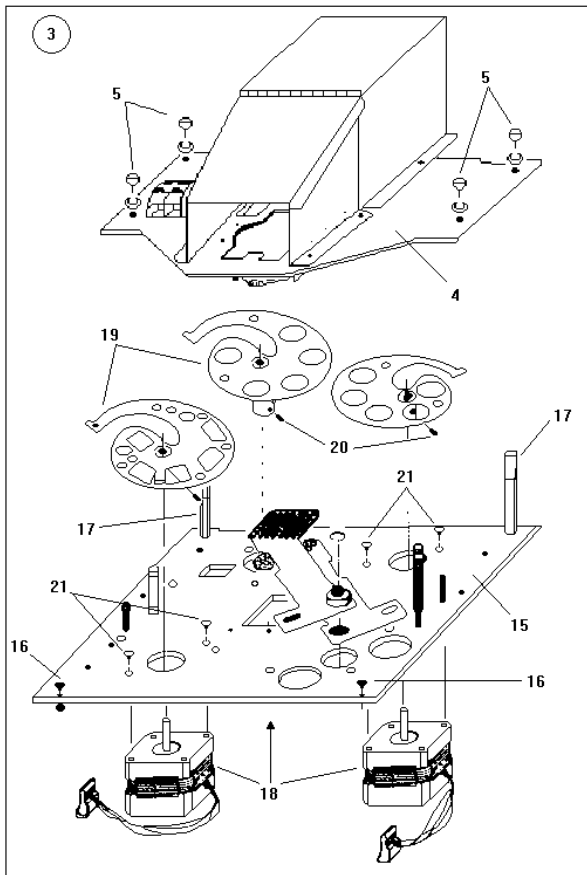

1. Open enlarger head.
2. Release holding plate (4) via screws (5).
- 3 Remove support plate (15) by releasing screws (16) and spacing bolts (17).
4. Release motors (18) from disk cams (19) by opening grub screws (20).
5. Unscrew motors (18) via screws (21) and unplug from insert plate.

Exchanging the microswitches

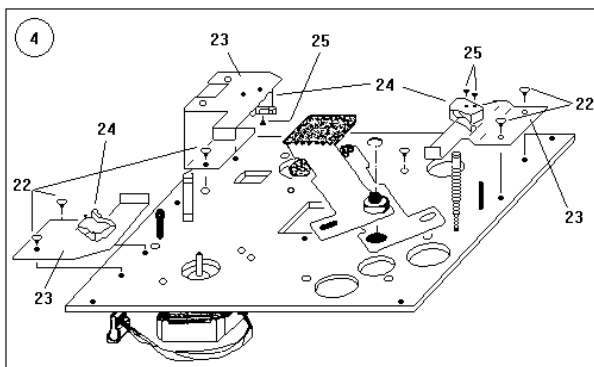

1. Release screws (22) and remove stop bracket (23).
2. Then remove microswitches (24) via screws (25).

I-2.2.2

Exchanging the density filter motors

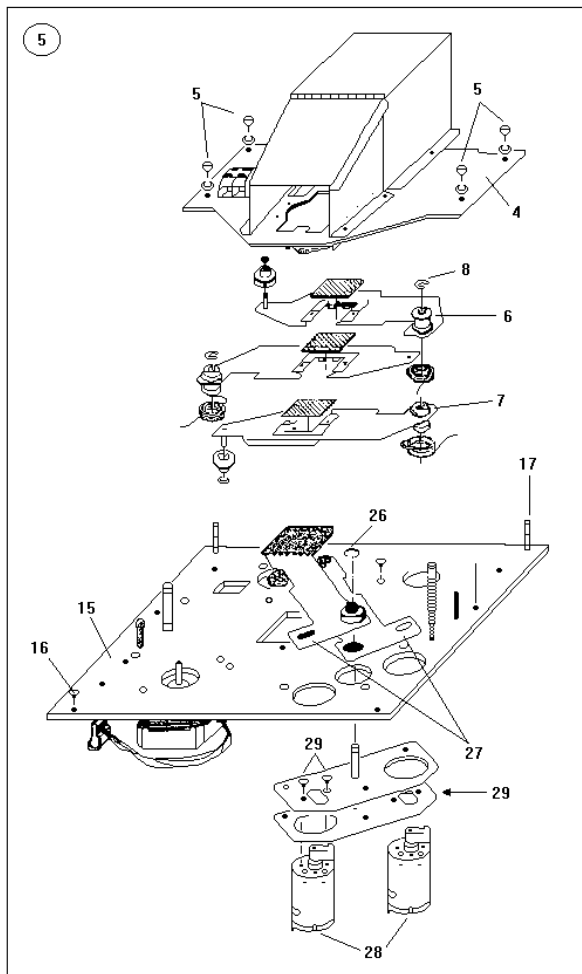

1. Open enlarger head.
2. Release holding plate (4) via screws (5).
3. Remove support plate (15) by releasing screws (16) and spacing bolts (17).
4. Release securing disk (26) and remove density blades (27).
5. To do this, the colour filter holders (6 + 7) must be released and removed via the securing disk (8).
6. Then the filter motors (28) can be removed via screws (29).

Exchanging the heat protection filters

Before exchanging these components, the measuring values in the test program should be noted. Proceed as follows.

- Enter test 15 in test program and swing out all density blades with key "1".
- Go from test 15 to test 16 and press "light" key.
- Make sure that mixing box 450 is fitted.
- Input filter settings Y=000, M=000, C=000 and press "YMC" key (↓).
The values to be noted appear in the 3rd LCD line.
- Switch enlarger off again.

I-2.2.3

Exchanging the heat protection filters under the lamp mounting

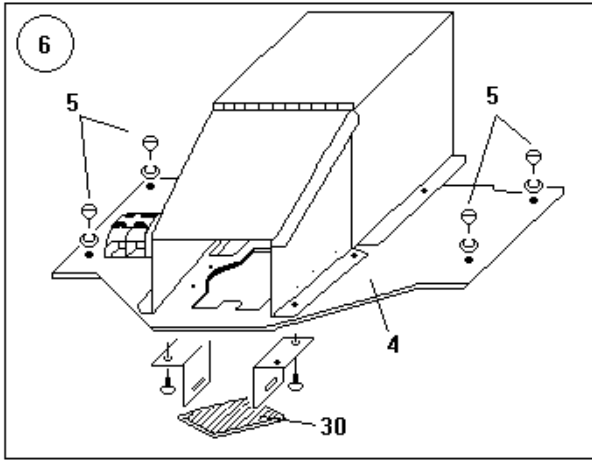

- Open enlarger head.
- Release holding plate (4) via screws (5). Heat protection filter can be exchanged.

Exchanging the heat protection filters under the mixing box

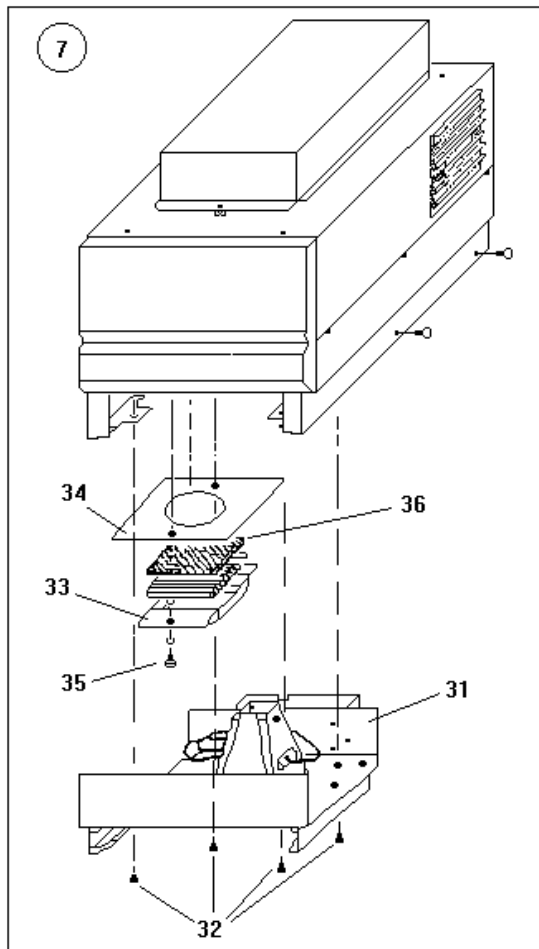

- Remove negative carrier and mixing box.
- Remove enlarger head.
- Remove light-box holder (31) by opening the screws (32).
- Carefully remove the heat protection filter (33) and plate (34) via screws (35) (circular diffusion rods may fall out).
- Exchange heat protection filter (36).
- Then return to test 16 in the test program.
- Fit mixing box 450, press "light" and "YMC" (↓) keys.
- Using trimmers, adjust Y, M, C (4 V white light) on Picto colour sensor PCB (under enlarger head) so that they correspond to the measuring values noted.
- Switch off enlarger and replace enlarger head.

I-2.2.4

Exchanging the shutter motor

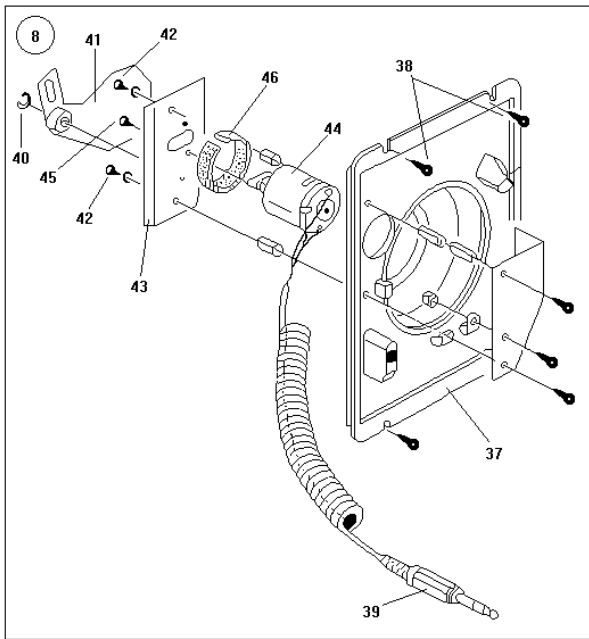

1. Remove lens plate (37) via screws (38).
2. Remove plug (39).
3. Remove securing disk (40) and withdraw shutter blade (41).
4. Release screws (42) and take out holding plate (43) with motor (44).
5. Then release screws (45) and detach cables from motor (44).
6. Remove light insulation (46) and glue onto new motor (44).
7. Fit new motor and re-assemble.

Section II

VCNA-feature for Pictochrom + and Pictochrom + AF

Factor Potentiometer PCB replacement and calibration:

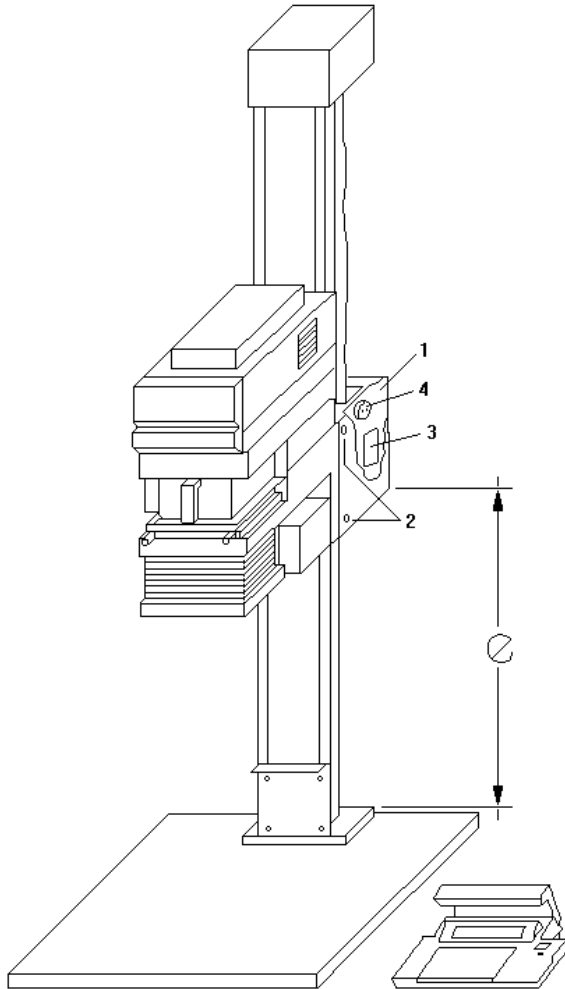

A correct adjustment of this potentiometer is important for a good and exact work with the Pictochrom + / AF.

The potentiometer is used to stabilize the correct color head position for calculation of exposure times and for slope compensations.

Procedure:

Open cover (1) by loosening screws (2).

The „Factor Pot PCB“ (3) and the factor potentiometer (4) are located on the right side.

Calibration:

Enter into the test program by closing the Dipfix switch S2 on the „Microcontroller PCB“.

Power on.

Enter into the test step 12 by pressing „12“ on the numerical keyboard and confirm it with softkey „TEST“

```
TEST 12 - FOTOMETER MODE
LOG. SIGNALS Keys: 0/Clear
Factor A/D = _____ L = _____
Y, M, C, D ____:____:____:____:____:_____
```

The display shows:

Move color head to the lowest position with the „Size/Head adjust“ keys on the Elite console.

Attention: remove the two limit rubber stoppers.

Adjustment of factor potentiometer (4)

The potentiometer is located on the right side of the transport carrier.

Measure on the factor potentiometer between pin 2 and 3 and turn axle to obtain 450Ω (+/- 100).

- Move color head to the position „REF 2“ of $e = 1082$ mm (+/- 0.5) - see drawing
Note the L-value on the display (3. LCD line) as L_{max} .
- Move color head to the position „REF 1“ of $e = 192$ mm (+/- 0.5) - see drawing
Note the L-value on the display (3. LCD line) as L_{off} .

Calculation of L_{maxnew} :

$$L_{maxnew} = L_{max} - (L_{max} - L_{off} - 890) \times \frac{L_{max}}{L_{max} - L_{off}}$$

Note value L_{maxnew}

- Move color head back to the position „REF 2“ ($e = 1082$ mm) and adjust the trimmer R5 on the „Factor Pot PCB“ to obtain on the display $L = L_{maxnew}$.
- Move color head back to the position „REF 1“ ($e = 192$ mm) and adjust the trimmer R3 on the „Factor Pot PCB“ to obtain on the display $L = 400$.

Check:

Read L- value (= $L_{val 1}$) on position Ref 1

Read L- value (= $L_{val 2}$) on position Ref 2

$$L_{val 2} - L_{val 1} = 890 \pm 1$$

The difference 890 between position Ref 2 and Ref 1 should be the same as the calculated difference of the $L_{val(2-1)}$ values.

Section III

AF-control

Autofocus mechanism for Pictochrom + AF and Pictograph AF

Contents:

- 1 Introduction to AF-feature
 - 1.1 System characteristics, specifications and tolerances
 - 1.2 Power on cycle
 - 1.3 Error messages to AF-feature
 - 1.4 Initialisation
 - 1.5 Factor potentiometer replacement and calibration
- 2 Test program
 - 2.1 Processor keyboard display PCB
 - 2.2 Power supply
 - 2.3 Processor PCB
 - 2.4 Power control interface PCB
 - 2.5 Lens movement failure
- 3 Head movement failure
- 4 Motor control 24V PCB: description
- 5 Autofocus memory check
- 6 Z80 Test unit

1. Introduction to AF-feature

1.1 System characteristics, specifications and tolerances

Design concept:

The instructions given here refer exclusively to the autofocus control.

All instructions referring to the enlarger will be found in the Pictochrom, Pictochrom + and Pictograph repair section (SECTION I).

The autofocus control consists of the AF 2000 Mot, former Elite 2000 Mot, integrated in the power/control column.

This control unit is the one already used in the L1200 and M 805 AF.

The microprocessor of the Pictochrom +, Pictograph and the AF unit work independently of each other.

The Z 80 CPU is used in the AF unit.

Operation description:

The Pictochrom + AF and Pictograph AF are micro-processor controlled autofocus systems.

The autofocus system uses a potentiometer for feedback information about the colour heads vertical position.

The potentiometer resistance determines the duty cycle of monoflop V6 on the power control interface PCB.

During this duty cycle (3–6 ms) pulses of 1.2 MHz frequency are counted into binary counters V16 and V18. The duration of the duty cycle varies with the colour heads height and thereby the number of pulses counted by V16 and V18.

Thus A/D conversion takes place.

The microprocessor calculates the necessary lens displacement according to the programmed values. It activates the lens motor thru V13, V14 (IF PCB) and V2, V1 on the lens motor board PCB.

The lens motor is a 30VDC motor. Thus a feedback becomes necessary to determine the real lens displacement.

An optical disc in connection with an opto sensor (V9) supplies the necessary pulses via V2, V7 to the power control PCB.

III-1.1.1

The microcontroller switches the pulses via the NAND-Gates V15 to binary counter V16 and V18.

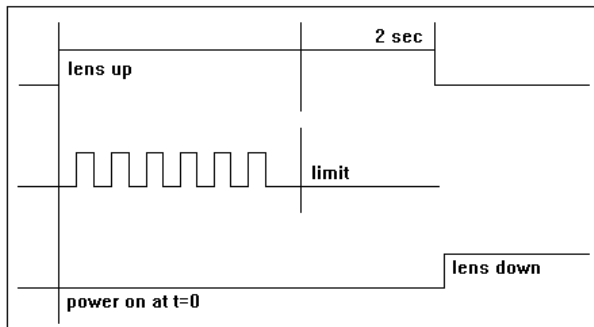

The lens reference position is determined after power on. The lens motor is activated and pulls the lens standard up to the stop position. Once the limit is reached, the optical disc stops supplying pulses. The microprocessor waits for approx. 2 seconds. If no pulses occur during this lapse, the position is taken for the upper lens limit position = ref. position.

The microprocessor fetches the programming values, the potentiometer limit values from the register and polls counter V16, V18 (for actual colour head position) to determine the necessary lens displacement.

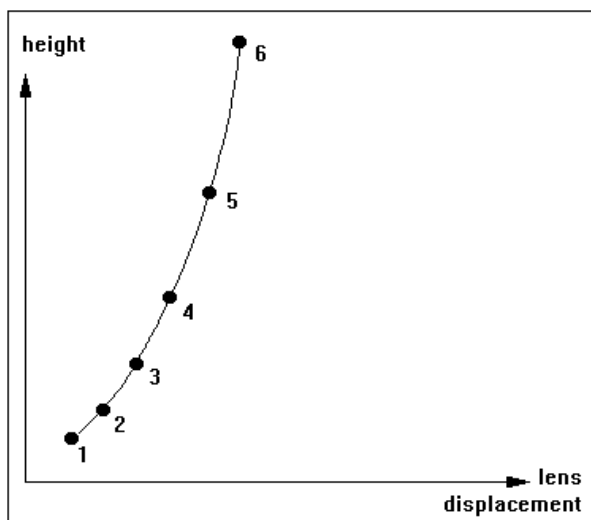

The programming values are determined during a programming session performed by the operator. The operator selects a channel and focuses the lens manually at 5 or 6 different head positions (see operator manual - table).

The microprocessor stores the number of pulses which occur during each focusing operation. Once the session is over, all intermediate points are approximated by a curve

Note:

The head limit positions are stored in two registers inside the RAM.

If the contents of the registers are lost, reprogramming becomes necessary (see factor potentiometer calibration: section III - point 1.5). Otherwise the unit can not operate !!!

Programming is effected via the AF-control unit on the power/control column. Selection of the lens channel, variations of the negative and positive variator (NV, PV) is done via the power/control column. Motor head adjustment and the function "film change position" can be activated from the operating console of Pictochrom + and Pictograph.

The "Light" and "Expose" keys, as well as the functions "Tim" and "FST", are no longer present.

Technical data:

Adjustment speed:	
Head fast:	approx. 8.2 cm/sec
Head slow:	approx. 6 mm/sec
Lens carrier fast:	approx. 7.2 mm/sec
Lens carrier slow:	approx. 1.2 mm/sec
Lens channels:	10 (0 - 9)
Usable focal lengths:	50 to 150 mm (180)
Resolution of the positioning system:	0.01 mm
Reproducibility of lens position:	± 0.02 mm
Range of positive variator (PV):	+999/-99 mm (1 Digit= 1 mm)
Range of negative variator (NV):	+99/-99 mm (1 Digit= 0.05 mm)

1.2 Power-on cycle

When the enlarger is switched on, the lens carrier moves upwards to the mechanical stop. Depending on the lens channel selected and the height of the enlarger head, the lens carrier moves to the focus position. The setup program of the basic equipment is identical to that of the manual enlarger.

If this position is not found, please check:

- whether the channel corresponds to the lens in use
- whether an error message appears on the control channel (Err 6 - Err 7).
- whether stored values have been lost
- whether RAM memory can not detect the top and bottom positions. The potentiometer value of these two positions must be re-stored (see page III-3.0)

1.3 Error messages to AF-feature

These error messages refer only to the AF unit and are displayed on the control unit (AF 2000 Mot) only.

Err 6

Cause:

Attempt to use more than 30 reference points for auto-focus programming or the memory channels have been overwritten by interference.

Remedy:

Press „Enter“.

Cancel all points as follows:

- Press „AF setup“ twice
- Press „Enter“ once
- Press „±“ (Clear) simultaneously and reprogram the autofocus

Err 7

Cause:

Error in the autofocus system. The lens carrier movement is blocked. The count pulses in the unit are missing or are not recognised. The pulse sequence is too slow or the channel is interrupted.

Remedy:

- Press „Enter“ twice.

No result:

- Re-initialise the unit
- Check the motor control

E

Cause:

The RAM has lost all values.

Remedy:

Re-initialise the unit (section III-1.4)

- Then re-program

Note:

If after programming, the enlarger does not move to focus positions without an error message appearing, re-initialise the enlarger and read in length of column (page III-3.0).

1.4 Initialisation

The RAM memory of the AF unit can be re-initialised by simultaneously pressing the keys „Enter“ and Lens adj. „↓“ and „↑“ and subsequently switching the enlarger on.

All values stored are erased during this procedure.

All stored values for the lens channels and the column reference values will be lost.

Before re-programming the focus go through the following procedure:

Action	Purpose
1. Press and hold the „Enter“ key. Power up.	Entry into test program.
2. Press „Enter“.	Exit from keyboard test: The unit displays a number except 0.
3. Press the „AF setup“ and „Enter“ keys simultaneously.	Entry into factor calibration procedure. The „NV“ LED turns on.
4. Move head to lowest position. Press „Enter“.	Lowest head position value is stored. The „PV“ LED turns on.
5. Move head to highest position. Press „Enter“.	Highest head position value is stored. The „PV“ LED turns off.
6. Power off to exit.	

This procedure initialises the head limit position registers.

The potentiometer values in highest and lowest head position are stored in the RAM. This obviates a precise mechanical adjustment.

1.5 Factor potentiometer replacement and calibration

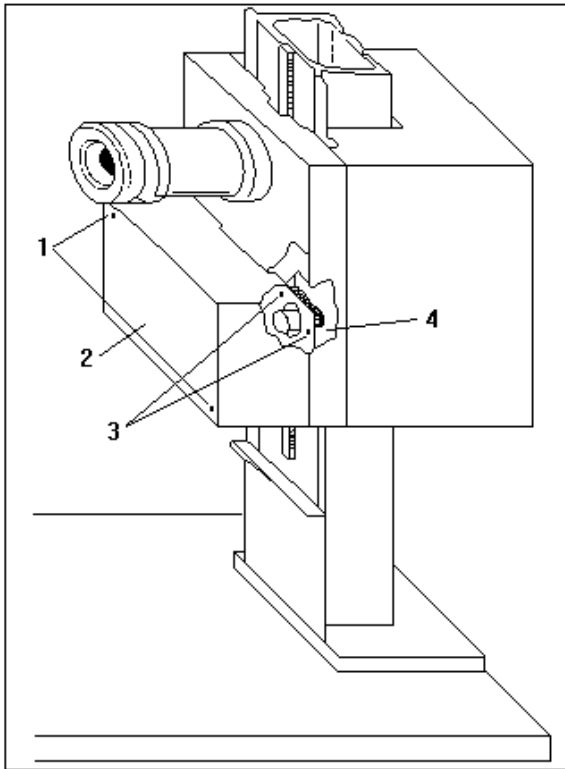

Replacement

1. Move head to lowest position.
2. Remove screws (1) and cover (2).
3. **Attention:**
Block the enlarger head mechanically, it might speed upwards.
4. Install new potentiometer on support plate (4).
Turn axle clockwise to stop.
5. Turn axle counterclockwise for 1/2 revolution.
6. Fix potentiometer.
7. Re-assemble in reverse order.

Calibration

Action	Purpose
1. Press and hold the „Enter“ key. Power up.	Entry into test program.
2. Press „Enter“.	Exit from keyboard test: The unit displays a number except 0.
3. Press the „AF setup“ and „Enter“ keys simultaneously.	Entry into factor calibration procedure. The „NV“ LED turns on.
4. Move head to lowest position. Press „Enter“.	Lowest head position value is stored. The „PV“ LED turns on. The „NV“ LED turns off.
5. Move head to highest position. Press „Enter“.	Highest head position value is stored. The „PV“ LED turns off.
6. Power off to exit.	

III-1.5.1

This procedure initialises the head limit position registers.

The potentiometer values in highest and lowest head position are stored in the RAM. This obviates a precise mechanical adjustment.

2 Test program

In case the part causing the problem is not evident, use this procedure to localise it.

The steps must be executed in sequence, do not jump steps as the logical reasoning behind this works per exclusion.

When a problem occurs, the most successful way to track down the failure is indicated.

- A. Normal test program
- B. Continuous test program 1
- C. Continuous test program 2

A. Entry into normal test program

- Press and hold the „Enter key.
- Power on.
- All LEDs, displays are switched on for 1.5 sec.

Correct?

- N - The display does not lit up. Go to III-2.2.
- The unit enters the operation mode.
Go to III-2.1.
- Go to processor PCB check (III-2.3).

Keyboard test:

Press any key except „Enter“ key.

Key:	Code:
Display select	016
Lens up	008
Lens down	004
AF setup	002
-	080
+	072
CH lens	068
Size/head adjust (*)	
head up	136
rapid	132
Head down	130

(*) These keys can be activated only in the test program on the AF unit.

Press the „Enter“ key.

The display shows the factor value.

Correct?

- N - Go to III-2.4.

III-2.0.1

Move head to lowest position: approx. 1600

Correct?

N - - Go to III-2.4.

Move head to highest position: approx. 9130
(Tol \pm 20 %)

Correct?

- N - Go to III-2.4.

Press the „Select“ key.

The display shows the counter value of the encoder (0).

Check the lens stage movement.

Press:	Action:
Lens ↓	Lens stage speed: 0.5 mm/sec downwards
Lens ↑	Lens stage speed: 0.5 mm/sec upwards
Lens ↓ and „-“	Lens stage speed: 6.5 mm/sec downwards
Lens ↑ and „-“	Lens stage speed: 6.5 mm/sec upwards

Correct?

- N - Go to III-2.5.

Encoder test:

1. Move the lens stage upwards until it stops (reference position).
2. Press the „Select“ key twice to zero the counter.
3. Move the lens stage downwards until the counter shows about 4000 (important: don't use „up“ key).
4. Note this number = N1.
5. Move the lens stage to its upper position. The new number shown by the display is: $N = 2x N1$.

Correct?

- N - Go to III-2.5.

III-2.0.2

The hardware is fully operational. For correct operation of the automatic focusing system, the potentiometer values must have been initialised (3.0).

B. Entry into continuous test program 1

- Press and hold „Enter“ key.
- Power on.
- Press the lens „up“ and „down“ keys simultaneously.
- Lens stage moves down for 30 mm. Stops. Moves up to ref. position.

C. Entry into continuous test program 2

- Power off to exit test program 1.
- Power on with „Enter“ key pressed.
- Move head to the first focusing position of channel 0. Press lens „up“ and „Select“ key.
- If channel 0 is programmed, and the potentiometer has been calibrated, the lens stage focuses as follows:

9 times random position

1 time focus position

2.1 Processor keyboard display PCB

All measuring takes place on the processor keyboard display PCB.

Connect the Z 80 TU.
Address switches to 8000.
Mode selector to „AD.STOP“.
Power on.

TU = 8000 and „RD“ LED on.

Correct?

- N - Go to III-2.3.

Check data display: FF!

Correct?

- N - Check for short or wrong key.
- Check V11.

Measure a L-level at V11/1.

Correct?

- Y - Go to III-2.1.2.

- N Measure all levels at V10/1.

Correct?

- N - Replace V5.
- Check path.

Measure a L-level at V10/2, 3, 13, 14.

Correct?

- N - Check address lines.

Replace V10.

Measure a L-level at V9/6, 8, 11.

Correct?

- N - Replace V9.
- Check paths.

Set the address switches to 8003.
Press „Reset“ key.

Measure the levels at V9:
Pin 6 = L, 8 = H, 11 = H

Correct?

- N - Check V9.

Press the following keys on this PCB:

Key	Data
S11 (size/head adj. up)	F7
S12 (rapid)	Fb
S13 (size/head adj. down)	Fd

Correct?

- N - Check V11.
- Check keys.

Set the address switches to 8005.
Press „Reset“ key.

The TU shows: 8005 FF.

Measure the levels at V9:
Pin 6 = H, 8 = L, 11 = H

Correct?

- N - Check V9.
- Check paths.

Press the following keys on this PCB

Key	Data
S1 (-)	EF
S7 (+)	F7
S8 (CH lens)	Fb

Correct?

- N - Check V11, R15
- Check keys.

III-2.1.2

Set the address switches to 8000.
Press „Reset“ key.

The TU shows: 8000 (RD LED on)

Press the following keys on this PCB

Key	Data
S1 (select)	EF
S2 (lens adj. up)	F7
S3 (lens adj. down)	Fb
S4 (setup)	Fd
S5 (enter)	FE

Correct?

- N - Check V11.
- Check keys.

Go to III-2.3.4 ENTRY 1.

2.2 Power supply

Note:

The AF 2000 unit is supplied with power from the 100 V transformer output. This enables us to adapt the entire system (Pictograph / Pictochrom + AF) to the widest possible range of supply voltages via only one voltage selector. So the voltage selector on the power control interface PCB must remain set to 100 V.

All measurements refer to PCB power control.

Power on.

Measure the voltage at P1.
It must be 5 V (+0.2 / -0.05).

Correct?

- N - Power off.
- Open the 5 V bridge.
- Power on.

Measure the level at P1.

If there are 5 V: Check for shorted 5 V rail.

If there are not 5 V: Check the voltage selector (110 V).
Check R20, V22, C13.

Measure 5 V volt at:
V14, V17, V19 from pin 20 to 10.

Correct?

- N Check 5 V, ground rail.

Go to III-2.3.

2.3 Processor PCB

All ICs mentioned throughout this section are located on the processor keyboard display PCB.

Power on.

Measure the voltage at V3 from pin 14 to 7.
It must be 5 VDC (-0.05 / +0.15).

Correct?

- N - Check ground and 5 V rail.
- Check capacitors C1, C6, C9, C13, C15.
- Check all ICs.

Measure a signal of 2.45 MHz (period: 0.4 μ s) at V4/6.

Correct?

- N - Check V1, V2.

Power off.

Connect the Z 80 TU.

Set the mode selector to „stop“.

Power on.

Press (and release) the „reset“ key.

The TU displays 000 00?

Correct?

- N - Go to III-2.3.9.

Check the control LEDs.

MEM M1 RD WR

ON ON ON OFF

Correct?

- N - Check if corresponding control path is shorted.
- Replace V4.

Press and hold the „Reset“ key.

The TU must display FFFF FF.

Correct?

- N - Go to III-2.3.9.

Hold the „Reset“ key.

Check if all control LEDs are off.

MEM M1 RD WR

OFF OFF OFF OFF

- N - Check if corresponding path is shorted.
- Replace V3.

III-2.3.1

Release the „Reset“ key.
Press SSTEP and compare.

0001	21	MEM	M1	RD
0002	55	MEM		RD
0003	55	MEM		RD
0004	7E	MEM	M1	RD

Correct?

- N - Go to III-2.3.11.

SSTEP once.

The TU must display 555 XX (XX: any hex number).

Correct?

- N - Check if address bus lines are interrupted.
- Go to III-2.3.12.

Measure the levels at (RAM - Eprom)

V7/	1	2	3	4	5	6	7	8	19	22	23
	L	H	L	H	L	H	L	H	H	L	H

V6 /	2	23	26
	H	L	L

Correct?

- N Check if address lines are shorted or interrupted.

Press SSTEP key 5 times.

TU must display AAAAA XX (X = does not care).

Correct?

- N - Go to III-2.3.11.

Measure the levels at (RAM - Eprom)

V7/	1	2	3	4	5	6	7	8	19	22	23
	H	L	H	L	H	L	H	L	L	H	L

V6 /	2	23	26
	L	H	H

Correct?

- N Check if address bus lines are interrupted.

III-2.3.2

Press and hold the „Reset“ key.
Measure a H-level at V7/18.

Correct?

- N - Go to III-2.3.14.

Set the address switches to 4000.
Set the mode selector to „AD.STOP“.
Press and release the „Reset“ key.
The TU must display: 4000 (RD LED on).

Correct?

- N - Check V4, shorted RD line.

Measure a L-level at V7/18.

Correct?

- N - Go to III-2.3.11.

SSTEP once.
Check if the WR LED goes on.
RD LED goes off.

Correct?

- N - Check V4.
- Shorted RD/WR line.

Set mode selector to „stop“.
SSTEP once.
Measure a H-level at V7/18.

Correct?

- N - Go to III-2.3.11.

Measure a 1.2 MHz frequency at X1/2.

Correct?

- N - Replace V2.
- Check if path is interrupted.

Power off.
Measure the DCV at V7/24. More than 3.5 Volts.

- N Check battery on power control interface PCB as well as V1, V2, V3.

III-2.3.3

Power on.
Press „Reset“.
Set the mode selector to „run“.
Press the „Test“ key.
Measure at V1/6.

Correct?

- N - Go to III-2.3.13.

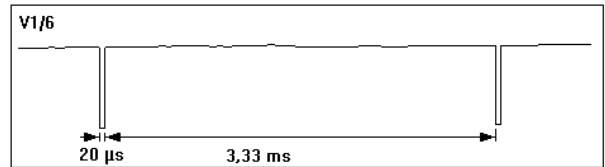

ENTRY 1

Set the ad. switches to 8000.
Mode selector to „AD.STOP“.
Press and release the „Reset“ key.
Press and release the „Test“ key.
Press „SSTEP“ until the TU displays: 8000 00.
Measure a L-level at V12/9.

Correct?

- N - Replace V10 and V9.

Set the mode selector to „stop“.
SSTEP once.
Measure a H-level at V12/9.

Correct?

- N - Replace V10 and V9.

Measure a H-level at V9/3.

Correct?

- N - Replace V10 and V9.

Measure a H-level at V10/1.

Correct?

- N - Check V5.
- Interrupted path.

III-2.3.4

Set mode selector to „AD.STOP“.

Set mode selector to „stop“.

TU = 800 20.

SSTEP once.

Measure a L-level on V12/6.

Correct?

- N - Replace V12.
- Check for interrupted data lines.

Measure the voltage at V14/collector.

- N - Replace V14.

Set the mode selector to „AD.STOP“.

SSTEP once.

Measure a H-level at V12/6.

Correct?

- N - Replace V12.

Check V14 collector ($V = 0V$).

- N - Replace V14.

Set ad. switches to 8004.

Mode selector to „AD.STOP“.

Press „Reset“.

The TU displays: 8004 FF.

WR + MEM LED on.

Measure H-levels at V28/18, 17, 14, 13, 8, 7, 4, 3.

Correct?

- N - Check for interrupted paths.

Check a L-level at V28/11.

Correct?

- N - Replace V10.
- Check for open path.

Set mode selector to „stop“.

SSTEP once.

Measure a H-level on V28/11.

Correct?

- N - Replace V10.
- Check for open path.

III-2.3.5

Measure H-levels at V28/19, 16, 15, 12, 9, 6, 5, 2.

Correct?

- N - Replace V28.

Press and release „Reset“.

Measure H-levels at V28/19, 16,15, 12, 9, 6, 5, 2.

Correct?

- N - Replace V28.

Set mode selector to „AD.STOP“.

Press the „test“ key.

SSTEP once: TU = 8004 00.

Measure L-levels at V28/18, 17, 14, 13, 8, 7, 4, 3.

Correct?

- N - Interrupted paths.

Set mode selector to „stop“.

SSTEP once.

Measure L-levels at V29/19, 16, 15, 12, 9, 6, 5, 2.

Correct?

- N - Replace V28.

Address: 8008.

Mode selector to „AD.STOP“.

Press „Reset“ key. TU = 8008 C0.

Measure a L-level at V29/11.

Correct?

- N - Replace V10.
- Check path V10 to V29.

Set mode selector to „stop“.

SSTEP once.

Measure a H-level at V29/11.

Correct?

- N - Replace V29.
- Check path.

Measure H-levels at V29/19, 16.

Correct?

- N - Replace V29.

III-2.3.6

Mode selector to „AD.STOP“.
Press the „test“ key.
SSTEP once. TU = 8008 00.
Measure H-levels at V29/19, 16, 15, 12, 9, 6, 5, 2.

Correct?

- N - Replace V29.

Set mode selector to „stop“.
SSTEP once.
Measure L-levels at V29/19, 16, 15, 12, 9, 6, 5, 2.

- N - Replace V29.

Set ad. switches to 8000.
Set mode selector to „AD.STOP“.
SSTEP until TU displays: 8000 40.
Mode selector to „stop“.
Measure H-levels at V12/11.

Correct?

- N - Replace V12.

Measure a L-level at V13 collector.

Correct?

- N - Replace V13.

SSTEP once.
Measure a L-level at V12/11.

Correct?

- N - Replace V12.

Measure the collector voltage of V13 ($V > 4.7$ V).

Correct?

- N - Replace V13.

Mode selector to „AD.STOP“.
SSTEP once. TU = 8000 80.
Measure a H-level at V12/11.

Correct?

- N - Replace V12.

III-2.3.7

Measure a L-level at V13/C and V14/C.

Correct?

- N - Replace V13. V14.

SSTEP twice. TU = 8000 10.

Mode selector to „stop“.

SSTEP once.

Measure a L-level at V12/3.

Correct?

- N - Replace V12.

Measure the voltage at V15 / collector ($V > 4.7$ V).

Correct?

- N - Replace V15.

Mode selector to „AD.STOP“.

SSTEP once. TU = 8000 20.

SSTEP once.

Check displays V17 and V19. Both must be on 8.

Correct?

- N - Replace bad display.
- Check shunted LEDs and displays.

SSTEP twice.

Check displays V16 and V18. Both must be on 8.

Correct?

- N - Replace bad display.

SSTEP 4 times.

All LEDs are lit (except V25).

Correct?

- N - Replace bad LED.

Mode selector to „stop“.

Press „Reset“

SSTEP until the TU shows: 0003 55.

Measure levels at plug X1/10, 12, 13, 14, 15, 16, 17, 18.

- N - Interrupted data paths.

The Microprocessor hardware is fully operational.

III-2.3.8

Check a H-level at V12/1

- N - Check if reset line is shorted.

Press and hold the „Reset“ key.
Measure a L-level at V12/1.

- N - Check if reset path is shorted or interrupted.

Release the „Reset“ key.
Check for a H-level at V7/18.

- N - Check for a H-level at V5/14.

Correct?

- Y- Check V1, V8.
- N- Check V5.

Check for a L-level at V6/20.

- N - Check the levels at V5 / 1 2 4 6
L L L H

Correct?

- Y- Replace V5.
- N- Replace V4.
 - Check for open path.

Power off.
Remove V6, V7 from their resp. sockets.
Power on.
Press and hold the „Reset“ key.
On TU address display appears FFFF.

- N - Check for grounded paths.
 - Replace V4, V9.

On TU data display appears FF.

- N - Go to III-2.3.10.

Release the „Reset“ key.
On TU display appears 0000 FF.

- N - Check for shorted paths.
 - Replace V4.

Replace V6, V7.
Check for interrupted address paths.

III-2.3.9

Measure H-levels at these ICs on the power control interface PCB.

V14/11,
V17/1, 19,
V19/1, 19

Correct?

- N - Replace V5.
- Check A15, A14 lines.

Shorted data line.

Replace V14, V17, V19 on power control interface PCB.

Replace V11, V12, V28, V29 on the processor PCB.

Press and release the „Reset“ key.

Measure a H-level at V7/18.

Correct?

- N - Check V1, V8, V5.

Measure a H-level at V4/25.

Correct?

- N - Check if corresponding path is shorted
(grounded).
- Replace V4.

Measure a H-level at V4/18.

Correct?

- N - Check for shorted pin.
- Replace V4.

Measure a L-level at V6/20.

Correct?

- N - Check V5.

Check for shorted address and data lines.
Replace V4. and V6.

Shorted address / data lines

Each digit in the TU displays the state of four address and data lines respectively. As the Z 80 has 16 address and 8 data lines, the TU needs 4 digits to read the address bus and 2 digits to read the data bus. Each half-byte (4 bits) is represented as a hexadecimal number. Consequently the first digit on the TU, starting left, shows the logic states of address lines A15-A12, the second one shows them from A8 to A11 and so on.

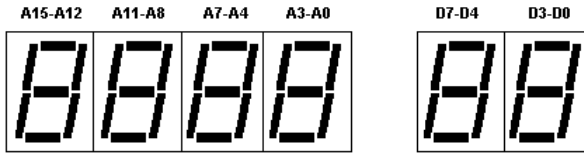

See also III-6.0.

Set the address switches to C000.
Set the mode selector to „AD.STOP“.
Press and release the „Reset“ key.

Measure a L-level at V1/3.

Correct?

- N - Replace V5.

Set mode selector to „stop“.
SSTEP once.

Measure a H-level at V1/3.

Correct?

- N - Replace V5.
- Check for shorted or interrupted path.

Measure the frequency at V3/8:

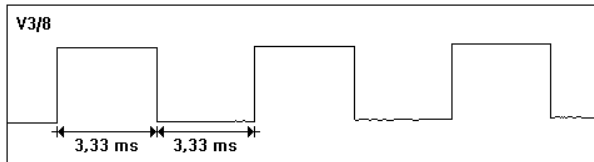

Correct?

- N - Check V3, V1.

Measure the frequency at V1/6:

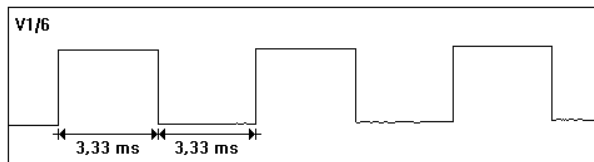

Correct?

- N - Check V1.

Replace in the following order: V7, V4, R4, V6.

Measure a H-level at V1/9.

Correct?

- N - Replace V4.

Measure a L-level at V1/8.

Correct?

- N Replace V1.

Replace V8.

III-2.3.14

2.4 Power control interface PCB

The processor PCB must be operational.
All measurements refer to the power control interface PCB.

Power off.
Remove lens motor plug X6 from the control channel.
Move head to midway (50 cm).

Measure the resistances 4b and 5a of the lens motor plug (KOhm) between contacts 4b and 5a of the lens motor plug.

$7 > R > 2.5$ (KOhm)

Correct?

- N - Check factor pot R1.
- Check calibration III-1.5.

Reconnect lens plug X6.
Press and hold the „Enter“ key.
Power on.
Thus the test program is selected.

All following measurements take place on the power control PCB.

Press the „Enter“ key once.
The unit exits the keyboard test and enters the potentiometer test.

Measure the signal at V6/3.

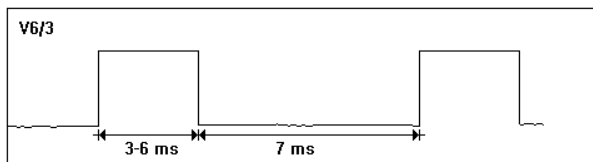

Correct?

- N - Go to III-2.4.4.

Measure the frequency at V15/1: 1.2 MHz.

- N - Check V5, clock line.

III-2.4.1

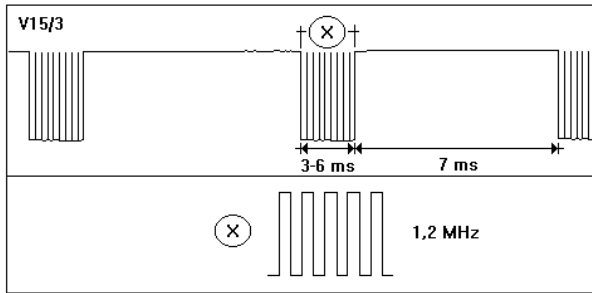

Measure the signal at V15/3.

Correct?

- N - Check V15.

Measure the signal at V15/1.

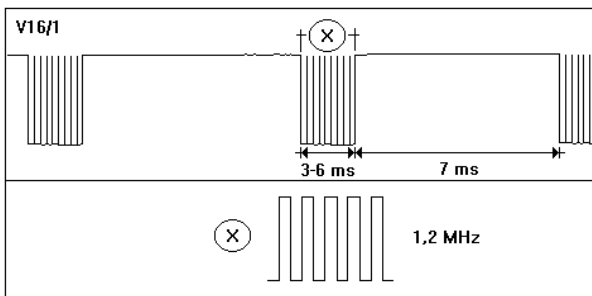

Correct?

- N - Go to III-2.4.6.

ENTRY 1

Power off. Disconnect lens motor plug X6.
 Connect the Z 80 test unit.
 Address switches: 800C.
 Set mode selector to „run“ (TU).
 Power on.
 Press „Test“ key (TU).
 Set mode selector to „AD.STOP“ (TU).

Press the „Enter“ key.
 The TU shows: 800C 00.

Press SSTEP twice (TU).
 The TU shows: 800C 01.

Measure the frequencies at V16, V18.

V16/	3	4	5	6	11	10	9	8
period	1.67	3.3	6.6	13.3	26.6	53.3	10.6	31.3
	µsec							

V18/	11	10	9	8	3	4
period	0.43	0.85	1.7	3.4	6.8	13.6
	ms					

III-2.4.2

Correct?

- N - The clear (CL) input (pin 2, 12) must be at L-level.
- If it is H, replace V5.
- Otherwise replace bad counter (V16 of V18).

SSTEP once.

TU shows: 800C 03.

Measure a H-level at V16, 18/2.

Correct?

- N - Check V5.

Measure L-levels at V16, V18/3, 10.

Correct?

- N - Check V16, V18.

Address switches: 8010.

Press „Reset“ key.

Measure L-level at V19/1, 19.

Correct?

- N - Go to III-2.4.7.

Address switches: 8020.

Press „Reset“ key.

Measure L-level at V17/1, 19.

Correct?

- N - Go to III-2.4.8.

Replace V17, V19.

III-2.4.3

All measuring takes place on the power control interface PCB.

Power off.
Connect the Z 80 TU.
Set mode selector to „AD.STOP“.
Address switches: 800C.

Power on.

Measure L-level at V6/2.

Correct?

- N - Reset cycle not correct: bad V22, C15.
- Replace V14.

SSTEP twice.

Measure the H-level at V6/2.

Correct?

- N - Go to III-2.4.5.

SSTEP once.

Measure +5 V at V6/6.

Correct?

- N - Check R6, factor pot, connection, V6.

Check C6, C5, V6.

III-2.4.4

All measuring takes place on the power control interface PCB.

Measure L-level at V14/11.

Correct?

- N - Replace V10, V9, V5 on the processor PCB.

Set mode selector to „stop”.
SSTEP once.

Measure a H-level at V14/11.

Correct?

- N - Replace V10 (processor PCB)
- Check S out path.

Replace V14.
Check paths.
Check V6, V5.

Measure a H-level at V15/5.

Correct

- N - Replace V14.
- Check path from V14/2 to V15/5.
- Check V5, V15.
- Check D1 data line.

Check V5, V4, V15.

III-2.4.6

All the following ICs are located on the processor PCB.

Measure the levels at V10: 1 2 3
L H L

Correct?

- Y - Replace V10.
- Check SIN 2 path.

Check the levels at V5. 1 2 3 4 6
L H L L H

Correct?

- N - Check paths.

Replace V5.
Check paths.

All the following ICs are located on the processor PCB.

Measure the levels at V10: 1 2 3
L L H

Correct?

- Y - Replace V10.
- Check SIN 1 path.

Check the levels at V5. 1 2 3 4 6
L H L L H

Correct?

- N - Check paths.

Replace V5.
Check paths.

2.5 Lens movement failure

Following failures are possible:

The lens motor moves only at fast speed.

- Y - To check out this failure go to III-2.5.5.

The lens motor moves only in one direction or does not move at all.

- Y - To check out this failure go to III-2.5.2.

The speed is not accurate:

1. Check spindle for dirt.
2. The low speed is achieved by pulsing the „up“ or „down“ command.

At fast speed the command stays at H-level at the time.

Neither the low nor the high speed are regulated and are therefore sensitive to lopsided mains voltages. To compensate, change R1 on the lens motor PCB.

III-2.5.1

Press the indicated keys and measure at V13 on the power control interface PCB.

Key	V13 / pin	level
up +	18	H
rapid	16	L
down +	18	L
rapid	16	H

- N - Go to III-2.5.3.

Press the indicated keys and measure at V2 on the lens motor PCB.

Key	V13 / pin	level
up +	1	L
rapid	2	H
down +	1	H
rapid	2	L

- N - There must be a voltage of 2 V at V2/4 and V2/6.
- Otherwise check R2, R5, C3, V2, C2, cables, connections.
- Check R6, R7, V2, cables, connections.

Check R1, R3, V1, motor.

Power off.
Disconnect lens motor plug X6.
Connect Z 80 TU.

Address switches: 800C
Mode selector „AD.STOP“.
Power on.

Measure a L-level at V14/11 (power control interface PCB).

Correct?

- N - Go to III-2.5.4.

Mode selector to „stop“.
SSTEP once.
Measure a H-level at V14/11.

Correct?

- N - Replace V10.
- Check S OUT path.

Mode selector to „AD.STOP“.
SSTEP until the TU displays: 800C 0A.
SSTEP once.
The TU still shows: 800C 0A.

Measure a H-level at V13/2.

Correct?

- N - Replace V14.
- Check D3 line, path from V13 to V14.

Press „Reset“: TU shows 800C 00.
SSTEP once.

Measure a L-level at V13/2.

Correct?

- N - Replace V14.
- Check D3 path.

Measure a L-level at V13/16.

Correct?

- N - Replace V13.

Check V13, V14, V9, D4 path.

III-2.5.3

All ICs are located on the processor keyboard display PCB.

Measure the levels at V10:

1	2	3	13	14
L	L	L	H	H

- N - Check address paths.

Replace V9, V10.

Replace WR line.

AF-module test

Press and hold the „Enter“ key.
Power on.
Press „Enter“ key.
Press „Select“ key.
Press the „up“ or „down“ key and the „-“ key.

All measurements take place on the power control interface PCB.

Measure the signal at V15/9.

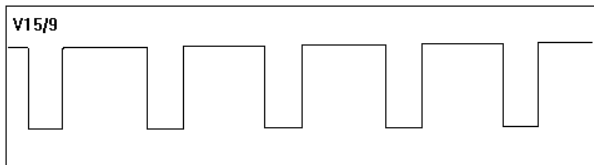

Correct?

- N - Go to III-2.5.6.

Measure at V15/11.

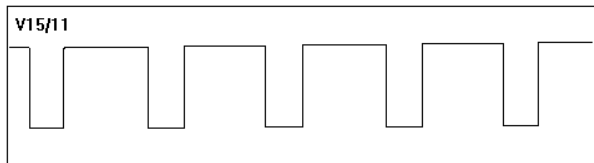

Correct?

- N - Check V15.

Go to III-2.4.2 ENTRY 1 to check counter (V16, V18).

Press the „up“ or „down“ and the „-“ key.
The lens must move at fast speed.

All measurements take place on the lens motor PCB.

Measure the signal at V9 /+C (see layout schematics).

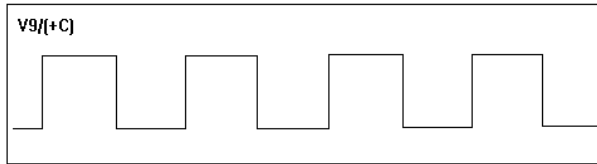

Correct?

- N - Check V9.

Measure the signal at V7/3.

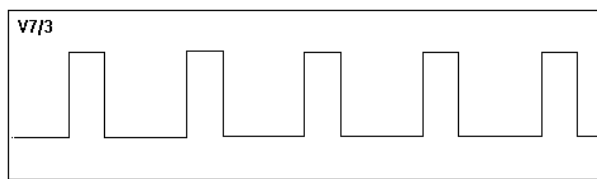

Correct?

- N - Replace V2, V7, V8.

Check R8, cables.

Check R5, V4, V5 on the power control interface PCB.

3 Head movement failure

Possible faults	Flowcharts
The head can not be moved from the control panel (LCD).	3.1
The head can not be moved at all.	3.2
The head can only be raised.	3.3
The head can only be lowered.	3.4
The head moves only at high speed (or low speed is not correct and can not be adjusted).	3.5
Flow charts	3.6

3.1 The head can not be moved from the control panel (LCD)

The head can not be adjusted via the Picto keyboard (operating console). Adjustment is possible via Head Adjust keys in control channel (directly on AF unit).

In order to undertake this adjustment from the operating console an interface PCB (Ailic interface) has been installed in the AF unit. This interface enables us to feed the functions „head up“, „head down“, „rapid“ and „film change position“ directly into the data bus of the AF 2000 processor keyboard display PCB.

These additional head control functions involve a change to the microcontroller PCB. The software has been exchanged. The hardware of the PCB has been supplemented by the addition of components V35 and V36.

Holding the keys on the operating console down, measure the following signals at V35 relative P0 on the microcontroller PCB:

„film change position“	V35/2	H	↯	L
„up“	V35/4	H	↯	L
„rapid“	V35/6	H	↯	L
„down“	V35/8	H	↯	L

- N - Check keys.
- Check data bus (test 3 on Picto TP).
- Check V44, V35, V36.

Ailic Interface:

The following inputs on the Ailic interface PCB are assigned.

- X1a/7 „up“ key
- X1a/8 „rapid“ key
- X1a/9 „down“ key
- X1a/3 „F. ch. position“ key

The following signals must appear when the keys are held down.

„up“	V1/8 relative P0	H	↯	L
„rapid“	V1/6	H	↯	L
„down“	V1/4	H	↯	L
„F.ch.pos.“	V1/17	H	↯	L

V1 receives the release signal via inputs 1G and 2G. Now the functions controlled from the operating console can be sent straight to the data bus of the AF 2000 unit.

III-3.1.1

Power off.
Connect the Z 80 on V4 (AF 2000 unit)
Address switches to 8030
Mode selector to „AD.STOP“.
Power on.

On TU display appears 8030 FF.
„RD“ LED on.

Press following keys on Picto keyboard and check data display.

Key	TU data
„up“	F7
„rapid“	Fb
„down“	Fd
„F.ch.pos.“	7F

- N - Check for correct connection on AF 2000 unit.
- Check +5 V on V1/20.

3.2 The head stage can not be moved at all

Are there $+24 \pm 4$ V at P8?

- N - Check connections.
- Check V1 and F1 on head motor interface PCB.

Are there $+12 \pm 0.5$ V at P7?

- N - Check V32, V33, V34, V35, R65.

Press and hold the key „head down“.
LED V16 is on. V18 is off.

Correct?

- N - Go to III-3.4.3.

Is there a H-signal at V25/5?

- N - Check V19, V21, path.

Is there a L-signal at V17/12 and 9?

- N - Check V26, path.

Is there a H-signal at V26/3?

- N - Check V17, V19, V26.

Release the key „head down“.
Press and hold the key „head up“.
LED V18 is on. V16 is off.

Correct?

- N - Go to III-3.6.4.

Press and hold the „head up“ key.
Is there a H-signal at V25/1?

- N - Check V19, V21.

Is there a H-signal at V26/4?

- N - Check V17, V19, V26.

Release the key „head up“.

Is there a sawtooth voltage at V20/6 as per diagram?

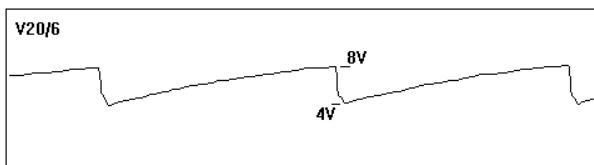

- N - Check V20.

III-3.2.1

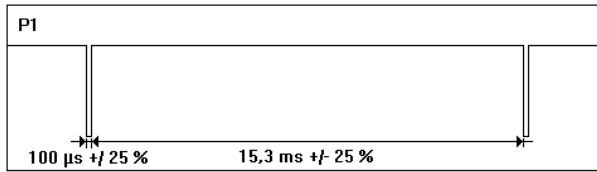

Are there negative pulses at P1 as per diagram?

- N - Check V20.

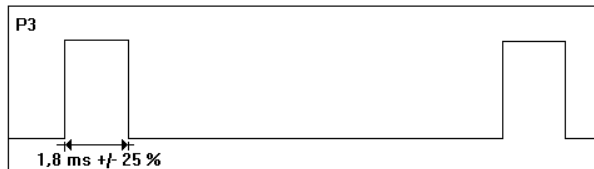

Are there positive pulses at P3 as per diagram?

- N - Check V15.

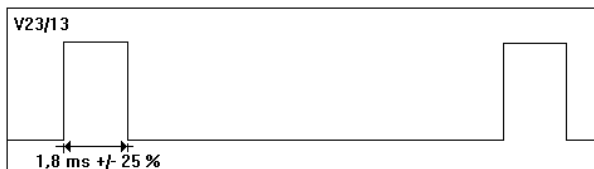

Press and hold the key „head down“.
Are there following pulses at V23/13?

- N - Check V25, V15.

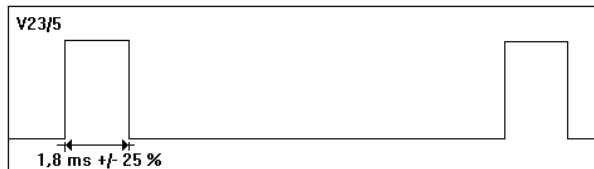

Release the key „head down“.
Press and hold the key „head up“.
Are there following pulses at V23/5?

- N - Check V25.

Release the key „head up“.
Is there a H-signal at P2?

- N - Check V36, V42 and motor resp. setting of trimmer R67.

Is there a H-signal at V21/11?

- N - Check V21.

Is there a L-signal at V10/8?

- N - Go to III-3.6.1.

Press and hold the key „head down“.
Are there +2 V at P4?

III-3.2.2

- N - Check V24 resp. setting of trimmer R46 (min. speed).

Are there following pulses at P6?

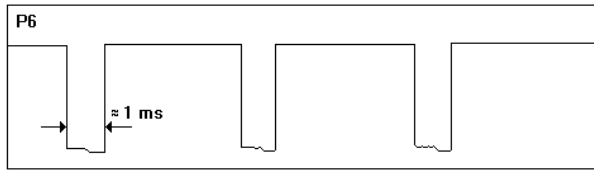

- N - Check V24.

Are the same pulses, inverted at V25/4?

- N - Check V10, V25.

Release the key „head down”.
Press and hold the key „head up”.
Are the same pulses at V25/3?

- N - Check V10, V25.

The faults are at V27, V29, V34, V40, V45, V46, V47, V48, V49, V50.

III-3.2.3

3.3 The head can only be raised

Press and hold the „head down“ key.

LED V16 must come on.

LED V18 must be off.

- N - Go to III-3.6.2.

Press and hold the „head down“ key.

Is there a H-signal on V25/5?

- N - Check V19, V21.

Press and hold the „head down“ key.

Measure following signal at V25/4.

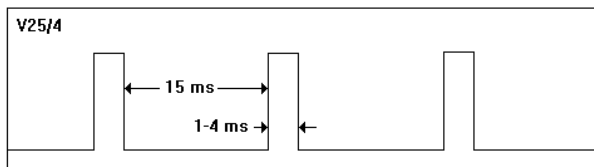

Correct?

- N - Go to III-3.3.3.

Hold the „head down“ key.

Measure the signal at V29/collector.

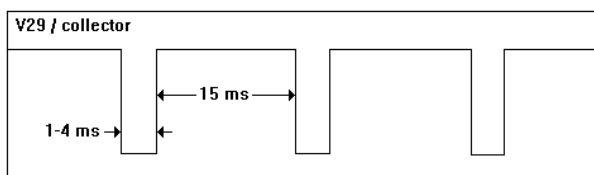

Correct?

- N - Replace V29.

- Check R56, R66 path.

Press and hold the „head down“ key.

Measure 8.2 V across V41.

Correct?

- N - Go to III-3.3.3 ENTRY 1.

Press and hold the „head down“ key.

Measure 0 V at V38.

Correct?

- N - Go to III-3.3.4.

Release the „head down“ key.

Measure 8.2 V across V38.

Correct?

III-3.3.1

- N - Go to III-3.3.4.

Press and hold the „head down“ key.
Measure 24 V at V27/collector.

Correct?

- Y - Check V37, V42, V47, V48.

Measure a L-level on V25/3.

Correct?

- Y - Check V25, V27.

Check V19, V21, V25.

III-3.3.2

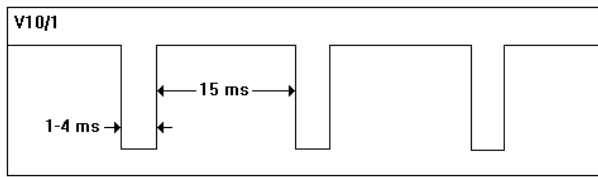

Press and hold the „head down“ key.
Measure the signal at V10/1.

Correct?

- Y - Check V10, V25.

Press and hold the „head down“ key.
Measure a H-level at P2.

- N - Adjust R64.
- Check V27, V37.

Hold the „head down“ key.
Measure the pulses at V23/13.

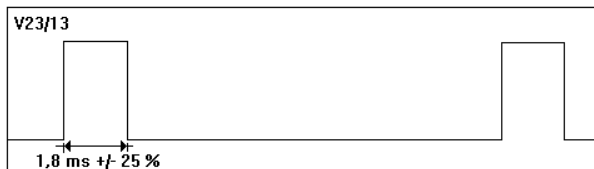

Correct?

- N - Check V25.

Check V24, V20.
Replace V23.

ENTRY 1

Press and hold the „head down“ key.
Measure a H-level at V26/3.

Correct?

- Y - Check V40, V41, R57.

Measure a H-level at V17/10.

Correct?

- Y - Check V19, V26.

Check V17.

Press and hold the „head down“ key.
Measure a L-level at V26/4.

Correct?

- Y - Check V37, V38, R55.

Release the „head down“ key.
Measure a H-level at V26/4.

Correct?

- Y - Check R55, V38.

Press and hold the „head down“ key.
Measure a L-level at V17/11.

Correct?

- Y - Check V19, V26.

3.4 The head can only be lowered

Press and hold the „head up“ key.
LED V16 must be off.
LED V18 must come on.

Correct?

- N - Go to III-3.6.4.

Press and hold the „head up“ key.
Measure a H-level at V25/1.

Correct?

- N - Check V19, V21.

Hold the „head up“ key.
Measure the signal at V25/3.

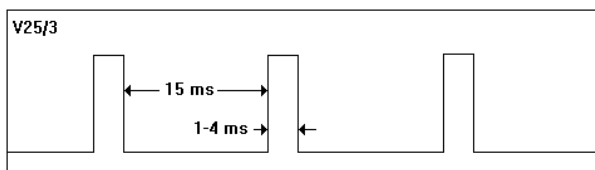

Correct?

- N - Go to III-3.4.3.

Hold the „head up“ key.
Measure the signal at V27/collector.

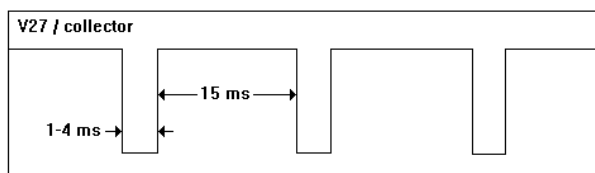

Correct?

- N - Replace V27.
- Check R67, R58 path.

Press and hold „head up“ key.
Measure 8.2 V across V38.

Correct?

- N - Go to III-3.4.3 Entry 1.

Press and hold „head up“ key.
Measure 0 V across V41.

Correct?

- N - Go to III-3.4.4.

III-3.4.1

Release the „head up“ key.
Measure 8.2 V across V41.

Correct?

- N - Go to III-3.4.4.

Press and hold the „head up“ key.
Measure 24 V at V29/collector.

Correct?

- Y - Check V40, V39, V45, V46.

Measure L-level at V25/4.

Correct?

- Y - Check V25, V29.

Check V19, V21. V25.

III-3.4.2

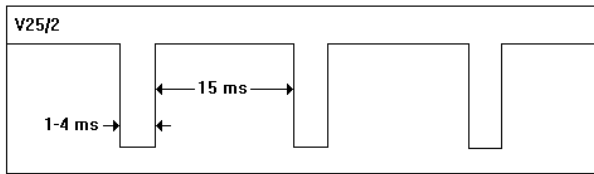

Press and hold the „head up“ key.
Check the signal at V25/2.

- Y - Check V25.

Hold the „head up“ key.
Measure the H-level at P2.

Correct?

- N - Adjust R64.
- Check V27, V37.

Hold the „head up“ key.
Measure the pulses at V23/5.

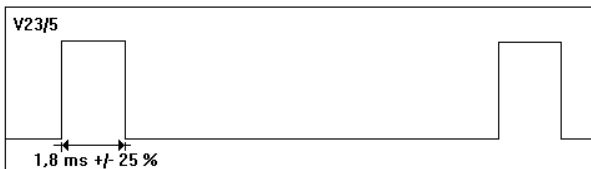

Correct?

- N - Check V25.

Check V24, V20.
Replace V23.

ENTRY 1

Press and hold the „head up“ key.
Measure a h-level at V26/4.

Correct?

- Y - Check V37, V38, R55.

Measure a H-level at V17/11.

Correct?

- Y Check V19, V26.

Check V17.

Press and hold the „head up“ key.
Measure a L-level at V26/3.

Correct?

- Y - Check V40, V41.

Release the „head up“ key.
Measure a H-level at V26/3.

Correct?

- Y - Check R57, V41.

Press and hold the „head up“ key.
Measure a L-level at V17/10.

Correct?

- Y - Check V19, V26.

Check V17.

3.5 The head moves only at high speed (or low speed is not correct and can not be adjusted)

The head moves only at low speed.
Measure a H-level at R8.

Correct?

- N - Go to III-3.6.1.

Press and hold the „head up“ and „rapid“ keys.
Measure a L-level at R8.

Correct?

- N - Go to III-3.6.1.

Press and hold the „head up“ and „rapid“ keys.
Measure a H-level at V10/8.

Correct?

- N - Check V10.

Press and hold the „head up“ and „rapid“ keys.
Measure the pulses at P1.
Compare with the wave form as per diagram..

Correct?

- N - Check V20.

Measure the time delay of 500 msec. between the trigger pulse at P1 and the negative leading edge at P3 as per diagram.

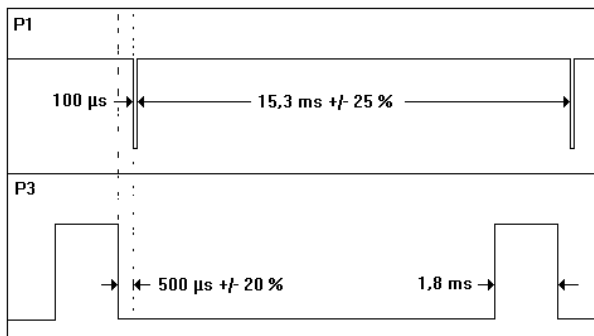

Correct?

- N - Adjust with R25.

Set the head to center position.
Press the „head up“ key.
Measure the signals at V23/5.
They must correspond to the signals at P3.

- N - Check V25.

III-3.5.1

Press the „head down“ key.
Measure the signal at V23/13.
It must correspond to the signal at P3.

- N - Check V25.

Press and hold the „head up“ key.
Measure 2V at P4.

Correct?

- N - Adjust with R46.
- Check V24, V10.

Check V23, V24, V10.

3.6 Flow charts

Press the keys indicated and measure at V13 on power control interface PCB.

Key	V13 / pin	level
head up	14	H
	12	L
	9	L
head down	14	L
	12	H
	9	L
rapid	14	L
	12	L
	9	H

- N - Go to III-2.5.3.

Check on power control interface PCB:

- V10, V11, V12.
- R9, R10, R11.
- Connection.

Check on head motor interface PCB:

- R1-R9.
- V2-V6.

Measure a L-level at R2.

Correct?

- N Is head in lowest position?
 - N - Check bottom limit switches.
 - Check limit switches on lens support.
- Y - Press and hold the „head up“ key.
 - Check LEDs V16, V18.
 - V18 is on. V16 is off.

N- Go to III-3.6.4.

Y- Go to III-3.4.1.

Press and hold the „head down“ key.
Measure a L-level at R15.

Correct?

- N - Go to III-3.6.1.

Release the „head down“ key.
Measure a H-level at R15.

Correct?

- N - Check V14.

Press and hold the „head down“ key.
Measure a H-level at V3/10.

Correct?

- N - Check V3, V10.
- Check for short inputs of V25.

Press and hold the „head down“ key.
Measure a H-level at V3/4.

Correct?

- N - Check V3, V26.

Press and hold the „head down“ key.
Measure a L-level at V3/11.

Correct?

- N - Check V3, V10.
- Go to III-3.6.4.

III-3.6.2

Hold the „head down“ key.
Check for L-level at V26/9.

Correct?

- N - Check for interrupted path.

Hold the „head down“ key.
Check for H-level at V26/8.

Correct?

- N - Check V3, path.
- Check V25.

Release the key and measure again.

L-level?

- N - Go to III-3.6.4.

Measure a L-level at V3/5.

Correct?

- N - Replace V26.

Press and hold the „head down“ key.
Measure H-level again.

Correct?

- N - Replace V26.
- Check path.

Check V3, V16 LED.

III-3.6.3

Measure a L-level at R5.

Correct?

- N - Is head in highest position?
 - N - Check top limit switch.
 - Check limit switches on lens support.
- Y - Go to III-3.3.1.

Press and hold the „head up“ key.
Measure a L-level at R11.

Correct?

- N - Go to III-3.6.1.

Press and hold the „head up“ key.
Measure a H-level at V3/11.

Correct?

- N - Check V3, V10.
- Check for short inputs on V25.

Press and hold the „head up“ key.
Measure a H-level at V3/3.

Correct?

- N - Check V3, V26.

Press and hold „head up“ key.
Measure a L-level at V3/10.

Correct?

- N - Check V10, V3.

Hold the „head up“ key.
Check for L-level at V26/8.

Correct?

- N - Check for interrupted path.

Hold the „head up“ key.
Check for H-level at V26/9.

Correct?

III-3.6.4

- N - Check V3, path.
- Check V25.

Release the key and measure again.

L-level?

- N

Measure a L-level at V3/2.

Correct?

- N - Replace V26.

Press and hold „head up“ key.
Measure again.

H-level?

- N - Replace V26.
- Check path.

Check V3, V18 LED.

4 Motor control 24 volt PCB

Functional description

Decoding stage

It consists of V3, V10, V26.

The commands UP, DOWN and FAST are low active.

The inputs LIMIT SWITCH UP and DOWN are high active. The limit switches are closed when the head is not in the end position.

Thus, in the inactive state the limit switches connect these inputs to ground.

The NAND-GATES V3/c and V3/d decode the inputs.

Down V10/13	Up V10/11	Limit sw. up V10/3	Limit sw. down V10/5	V3/10	V3/11
L	H	L	L	H	L
H	L	L	L	L	H
H	X	H	L	L	L
X	H	L	H	L	L
X	L	L	H	L	H
L	X	H	L	H	L

V26/c is an EX-OR gate. If both the up and down commands are active, output pin 10 goes to L-level and stops the commands.

Pulse generator

Astable multi vibrator V20 produces pulses (pin 3) and a sawtooth (pin 6).

The sawtooth is compared to the feed-back voltage available at V24/1 via V24/d.

The duty-cycle at V10/2 is proportional to the feedback voltage.

Depending on the selected function (up or down), either V25/3 or V25/4 follows this frequency and switches transistor V29 (V27).

A larger load means a higher voltage at V24/1 and a longer duty cycle at V10/2.

If the „fast“ key is pressed, the pulses are suppressed via V10/d and replaced by a steady H-level. Thereby the motor receives full power instead of a pulsed signal.

V24/c is a time delay circuit to avoid a sudden voltage increase at the motor inputs.

Load feedback

At slow speed the load condition is measured and translated into a proportional pulse to the power drivers.

Across R53 (down) and R49 (up) the driving pulses are available.

Their amplitude decreases if the motor load increases, as the voltage drop across R68, R69 increases as well and less voltage reaches the motor.

The pulses charge C19 via digital switches V23/a (up) or V23/b (down).

Capacitor C19 charges up to a voltage proportional to the pulse amplitude.

At pin 7 of buffer V24/b the same voltage appears.

V24/a compares the desired speed (pin 3) to the feedback = actual speed.

The desired speed is adjusted via R46.

The voltage available at V24/1 is therefore proportional to the difference between desired and actual speed.

Via digital switches V23/a, b the feedback is synchronised to the control pulses; monostable V15 activates these switches to this purpose.

To achieve a high efficiency slow speed regulation, the motor speed is pulse-controlled.

The period of these pulses is sufficiently short to guarantee smooth motion.

The bridge configuration allows movement in both directions without the need of a dual supply voltage.

Overload protection

An electronic fuse protects motor and power stage from overload and short circuit.

The voltage drop across R68, R69 is proportional to the motor lead.

Part of this voltage drop reaches transistor V36. If it exceeds 0.7 volts, V36, V37 become conductive and trigger flip-flop V21/c, d.

Pin 13 of V24 is forced to L-level. Consequently V10/2 stays at L-level and the driving transistors are deactivated.

The motor current is interrupted.

Flip-flop V21 is reset by astable V20.

If the short-circuit condition persists, the flip-flop V21 is set again.

5 Autofocus memory check

MA6036P.1Z - Pictochrom + AF / Pictograph AF

This software allows you to control the stored autofocus values and factor potentiometer values with the aid of the test program (AF unit).

This is to check about lost datas, cause of autofocus failures.

A new function (calibration values) has been added in the test program.

For the Pictochrom /-graph units, in addition, it is now possible to start the mechanical stress test by pressing „up“ and „down“ keys on the Picto AF Keyboard simultaneously.

By a new installation of software:

After EPROM inserting the following must be performed.

- RAM initialisation
- Factor poti adjustment
- Lens channel re-programming (with the users manual)

RAM initialisation

Action	Purpose
Press and hold keys „enter“, „lens adj. ↓“ and „lens adj. ↑“ simultaneously. Power up.	All the memory will be lost.
Switch the unit on and off. Power off.	On the display appears „E“.

Adjusting the factor potentiometer

Action	Purpose
Press and hold the „Enter“ key. Power on.	Entry into test program.
Press „Enter“ key once.	Exit from keyboard test. The display shows a number except 0.
Press the keys „AF setup“ and „Enter“ simultaneously.	Entry into factor calibration procedure. The „NV“ LED turns on.

III-5.0.1

Action	Purpose
Move the head to lowest position. Press „Enter“ key.	The lowest head position value is stored. „PV“ LED turns on. „NV“ LED turns off.
Move the head to highest position. Press „Enter“ key.	The highest head position value is stored. The „PV“ LED turns off.

Power off.

Re-program the lenses following the users manual.

Enter the TP: press and hold „Enter“ key and power on.

Select calibration values mode by pressing „Enter“ key twice (test program steps: Display test - Control interface test - calibration values).
The display shows now the max. factor poti value.

All data can be read in the following sequence:

- Factor poti values

The display shows „P0“ while pressing and holding „display select“ key.

Index number	Description
0	Factor poti value maximum

Press „+“ key.
The display shows „P1“.

Index number	Description
1	Factor poti value minimum

Note: All other index numbers are insignificant.

- Lens calibration values

Index no.	Description
0	Enlarger head position (first position scale)
1	Enlarger lens position (first position scale)
2	Enlarger head position (second position scale)
3	Enlarger lens position (second position scale)
↓	
58	Enlarger head position (thirty position scale)
59	Enlarger lens position (thirty position scale)

III-5.0.2

Note:

A maximum of 30 position scales is possible.
Generally only the first 6 or 7 position scales are used, all others = 0.

How to show the calibration values

Note:

Of all indicated data a note must be made. So they can be compared resp. controlled again in a future time.

- With the „+“ and „-“ key the index no. can be decreased resp. increased.
By holding depressed the key, the actual index number appears in the display.

The „Display select“ key shows the actual index and channel number when kept depressed.

When the „+“ and „-“ keys are pressed simultaneously, the index no. returns to 0.

- Select the needed lens channel with the channel key. Every key pressure increases the channel number in this sequence: P, 0, 1, 29, P

P = Factor poti values

0-9 = Lens calibration values.

6 The Z 80 Test Unit

Test unit description

Under normal conditions the microprocessor system's program sequence will be executed within 1 to 4 μ s. However, since the order's effectiveness depends upon the functional conditions of approx. 28 signal lines a „real-time test“ is an almost impossible task when using normal testing equipment.

With the test unit it is possible to „slow down“ the program sequence and to process the single orders in a step-by-step fashion. All signal-conditions can be maintained indefinitely (until the execution of the subsequent order) and may thus be tracked with conventional measuring equipment, e.g. an oscillograph.

To do this just use test clip (12) to join the test unit to the microprocessor. The unit is then ready for operation.

Fig. 1 shows a front view of the test unit.

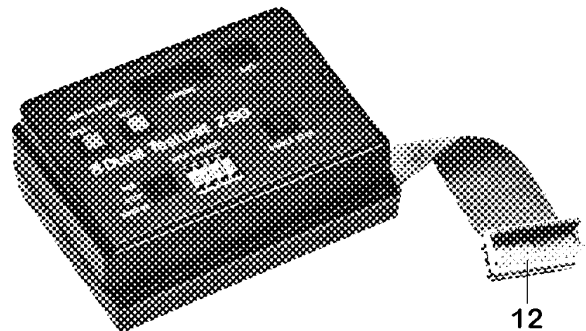

Here below you find a short description of the various displays and keys.

- * MEM LED (1):
To indicate that a memory component has been activated.
- * M1 LED (2):
To indicate that the data input is an OP-code. This is useful in case of orders consisting of several bytes.
- * RD LED (3):
To indicate that data are being read from a memory (READ).
- * WR LED (4):
To indicate that data are being written into a memory (WRITE).

III-6.0.1

- * ADDRESS DISPLAY (5):
To indicate the address being docked at the address bus.
- * DATA DISPLAY (6):
To indicate the datas being docked in the data bus.
- * RESET KEY (7):
With this key the microprocessor's RESET input may be activated. It must be pressed each time the unit is switched on.
- * TEST KEY (8):
This key interrupts the program sequence. It also starts the test program.
- * MODE SELECTOR SWITCH IN RUN POSITION (9):
The program being executed is stopped immediately and the order just being processed will be displayed.
- * MODE SELECTOR SWITCH IN A-STOP POSITION (9):
The program will be stopped only if the micro-processor's address matches the address selected with the „STOP ADDRESS (10) priority select switch.
- * STEP KEY (11):
By pressing this key, just one machine cycle will be executed as long as the mode selector switch is in the „STOP" position. In the „A-STOP" position, a program cycle will be run down (until the selected address is reached again).

Section IV

Kermit Data Saving on PC

Storing data on a floppy disk or hard disk of a personal computer (Memory dump - function)

The memory dump - function allows you to store all data (paper channel offset, job memories etc.) to a floppy disk or to the hard disk of the Personal Computer. This back-up-file can be loaded back into yhe enlarger if necessary.

Required items:

- Personal Computer with DOS-operating system
- Data transfer program, i.e.: KERMIT
- RS 232 C Interface cable as illustrated

The RS 232 C parameters on all Pictochrom and Pictograph are set to:

- 2400 Baud
- 7 Databit
- no parity
- 2 Stopbit

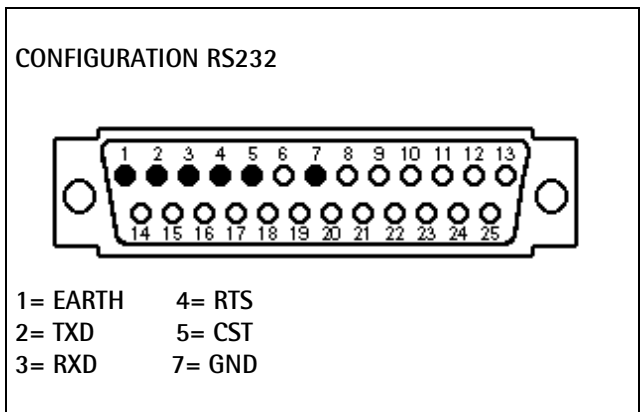
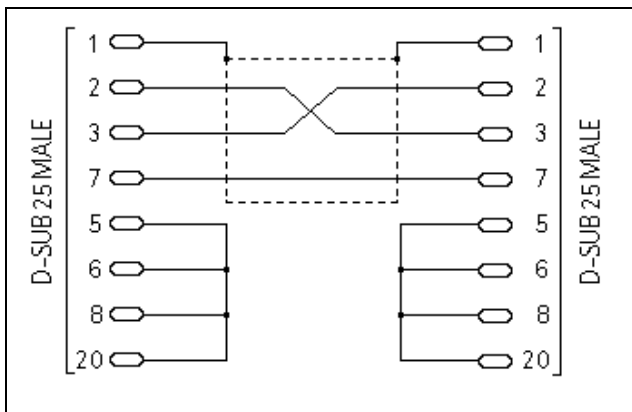

Connect the interface cable on the serial interface outlet (RS232) and on the Personal Computer RS 232 C outlet.

Data transfer from enlarger to the PC

Enter test program test 18 see section I-1.5

```
TEST 18 - TRANSMIT / RECEIVE RAM DATA
          TO / FROM A PC
----- Byte
          TRANSMIT      RECEIVE      EXIT
```

Activate memory dump-function on the enlarger.

The enlarger is now ready to receive / send data.

Kermit

Activate the data transfer program on the PC.

```
C:\KERMIT>kermit
IBM-PC MS-Kermit : 3.00 16 Jan 1990
Copyright (C) Trustees of Columbia University 1982, 1990.

Type ? or HELP for help

MS-DOS Kermit 3.0 initialization file. . .
Smile!
MS-Kermit>
```

If the data transfer program is loaded in a sub-directory, change first the directory and then start the program. The screen indicates the program version number and the Copyright note.

set speed 2400

log session Picto.RAM

connect

Input the data transfer speed and file name where the data will be stored.

i.e. " Picto.RAM " is the file name, input "connect" to start the program.

```
C:\KERMIT>kermit
IBM-PC MS-Kermit : 3.00 16 Jan 1990
Copyright (C) Trustees of Columbia University 1982, 1990.

Type ? or HELP for help

MS-DOS Kermit 3.0 initialization file. . .
Smile!
MS-Kermit>set speed 2400
MS-Kermit>log session Picto.RAM
MS-Kermit>connect
```

The PC is ready to receive data.

```

] ]
Esc-chr: ^D help: ^D? port:1 speed: 2400 parity:none echo:rem VT320

```

```

TEST 18 - TRANSMIT / RECEIVE RAM DATA
          TO / FROM A PC
----- Byte
          TRANSMIT      RECEIVE      EXIT

```

Start the data transfer program at the enlarger by pressing "Transmit". All data (RAM copy) will be transferred to the PC and stored in the file "Picto.RAM" on the hard disk.

Press the key "Transmit"

The counter in the enlarger display indicates the transferred byte.

```

34343434343456565656565656568787878782334545656657667676
] ]
Esc-chr: ^D help: ^D? port:1 speed: 2400 parity:none echo:rem VT320

```

```

TEST 18 - TRANSMIT / RECEIVE RAM DATA
          TO / FROM A PC
----- Byte
          TRANSMIT      RECEIVE      EXIT

```

The transferred bytes are counted down. Approx. after 3 1/2 min. the value reaches zero, that means all data are saved. Press stop to close the connection.

- Close the data transfer program.
- Press "Ctrl" and "+" simultaneously.

close session

exit

```
MS-Kermit>close section
  Closing Session log
MS-Kermit>exit
C:\KERMIT>
```

Data transfer from PC to enlarger

Enter test program test 18 see section I-1.5

Activate memory dump-function on the enlarger.

```
TEST 18 - TRANSMIT / RECEIVE RAM DATA
          TO / FROM A PC
----- Byte
          TRANSMIT      RECEIVE      EXIT
```

Kermit



Activate the data transfer program on the PC.

```
C:\KERMIT>kermit
IBM-PC MS-Kermit : 3.00 16 Jan 1990
Copyright (C) Trustees of Columbia University 1982, 1990.

Type ? or HELP for help

MS-DOS Kermit 3.0 initialization file. . .
Smile!
MS-Kermit>
```

If the data transfer program is loaded in a sub-directory, change first the directory and then start the program. The screen indicates the program version number and the Copyright note.

set speed 2400



Input the data transfer speed and press key " Enter ".
Input transmit Picto.RAM.

transmit Picto.RAM



Note:

Do not press " Enter ", first start the data transfer program at the enlarger.

```
C:\KERMIT>kermit
IBM-PC MS-Kermit : 3.00 16 Jan 1990
Copyright (C) Trustees of Columbia University 1982, 1990.

Type ? or HELP for help

MS-DOS Kermit 3.0 initialization file. . .
Smile!
MS-Kermit>set speed 2400
MS-Kermit>transmit Picto.RAM
```

```
TEST 18 - TRANSMIT / RECEIVE RAM DATA
          TO / FROM A PC
----- Byte
          TRANSMIT      RECEIVE      EXIT
```

Press the key "Receive"



Start the data transfer program at the enlarger by pressing "Receive".

Press the "Enter" key at the Personal Computer within 8sec. to start the data transfer.

Note:

When exceeding the 8sec. the enlarger return to the normal mode. Restart the data transfer program as mentioned above.

```
TEST 18 - TRANSMIT / RECEIVE RAM DATA
          TO / FROM A PC
----- Byte
          TRANSMIT      RECEIVE      EXIT
```

The counter in the enlarger display counts down the received bytes (transfer time approx. 3min.). "Stop" key stops the data transfer.

When counter shows "0" all datas have been transfered to the enlarger.



```
^D
MS-Kermit>exit
```

exit



Close the data transfer program at the PC, press the "Enter" key.

Input "Exit" and press "Enter". After successful data transfer, switch the enlarger off and on again, to start the setup cycle.

Section V

PCB Description	Diagram Code no.	Idx	Chrom CL	Chrom Plus	Graph	Chrom Plus AF	Graph AF	Pdf
Lamp EST UL 4501 (OLD Pcb)	1872650	--	X	X	X	X	X	X
Microcontroller PCB (A-Version)	AC48301	.0E	X	-	-	-	-	-
Microcontroller PCB (B-Version)	AC48303	.0E	-	-	X	-	-	-
Microcontroller PCB (D-Version)	AC48307	.2E	-	X	X	X	X	X
Picto Motor Control	AC48351	.0E	X	X	X	X	X	X
Wiring diagram - Chrom / Graph	AC48400	.2C	X	-	X	-	-	-
Wiring diagram - Chrom / Graph	AC48400	.5C	-	X	X	-	-	.6C
Wiring diagram - AF versions	AC48401	.3C	-	-	-	X	X	-
Wiring diagram - AF versions	AC48401	.6C	-	-	-	X	X	.7C
Picto Power Supply	AC48451	.3E	X	X	X	X	X	.6E
Picto Colour Signal	AL48301	.3E	X	X	X	X	X	.4E
Factor Pot. PCB	AL48451	.0E	-	X	-	X	-	.1E
Picto Keyboard Display	MA48201	.0E	X	X	X	X	X	X
Power Control Interface PCB	MA60201	.1E	-	-	-	X	X	X
Processor Keyboard Display PCB	MA60302	.2E	-	-	-	X	X	.3E
Motor Control +24 V (lens)	MA83305	.2E	-	-	-	X	X	.3E
Picto Probe	MB48201	.4E	-	X	X	X	X	.5E
Lamp EST UL 4501 (NEW Pcb)	MC48201	.0D	-	X	-	X	X	X
Picto AF Elite 2000 Ailic - interface	MP30202	.0E	-	-	-	X	X	X
Lens Motor	XA90201	.0E	-	-	-	X	X	X
Soldering plane layout lens motor	(XA9020A)	.0Z	-	-	-	X	X	X

durst

Durst Phototechnik
AG
Division Phototechnik
Postfach 223
Vittorio-Veneto-Straße 59
I-39042 Brixen, Italy
Telefon 0472/83 06 20
Telefax 0472/83 09 80
e-mail: durst@durst.it
e-mail service department: service@durst.it
Internet: www.durst-online.com / www.durst.it